



## Automatic Prediction and Identification of Smart Women Safety Wearable Device Using Dc-RFO-IoT

**Koppula Srinivas Rao\***

\*Corresponding Author, Professor in CSE, Department of Computer Science and Engineering, MLR Institute of Technology, Hyderabad. E-mail: ksreenu2k@gmail.com

**D. V. Divakara Rao**

Professor, Department of C. S. E, Raghu Engineering College, Dakamarri, Bheemunipatnam Mandal, Visakhapatnam, divakararao. E-mail: dusi@raghuenggcollege.in

**Ibrahim Patel**

Assoc. Professor Department of Electronics and Communication Engineering B V Raju Institute of Technology, Medak (Dist.), Narsapur. 502313 ibrahim. E-mail: patel@bvrit.ac.in

**K. Saikumar**

Department of ECE, Koneru Lakshmaiah Education Foundation, Green Fields, Vaddeswaram, Andhra Pradesh, India 522502. E-mail: saikumarkayam4@gmail.com

**D.Vijendra Babu**

Professor, Department of Electronics & Communication Engineering, Aarupadai Veedu Institute of Technology, Vinayaka Mission's Research Foundation, Paiyanoor-603 104. Tamil Nadu, India. E-mail: drdvijendrababu@gmail.com

---

### Abstract

Women's safety is very important for around the world and many anti-women safety incidents are happened in current decades. Women's criminality is on the rise in India, particularly on an hourly basis 1000 criminal cases are filed according to Indraprastha and Kannon organizations. The Internet of Things (IoT) application will assist women in difficult situations.

This design with Dc-RFO-IoT has an emergency application that can be useful to provide critical thinking and suggestions to women in rescue time. When the emergency soft button is pushed, notifications are sent to registered contacts as well as to women's hotline lines with GPS and GSM. A GPS sensor is also used to transmit the position with longitude and latitude. Every one minute, the receiver sends a link to your location, updating them on your current position. The attacker may shut the victim's mouth and prevent her from requesting assistance. The speaker on this gadget generates high-frequency sound. It will raise the alarm

in the surrounding area and make the attacker fearful. This IoT with deep learning application is giving accurate outcomes and measures are improved. The performance measures like accuracy 93.43%, sensitivity 92.87%, Recall 98.34%, safety ratio 97.34%, and F measure 97,89% had been improved these are outperformance the methodology and compete with present models.

**Keywords:** Smart Phone, IoT, GPS, Sensors.

Journal of Information Technology Management, 2023, Vol. 15, Special Issue, pp. 34-51

Published by University of Tehran, Faculty of Management

doi: <https://doi.org/10.22059/jitm.2022.89410>

Article Type: Research Paper

© Authors

Received: February 26, 2022

Received in revised form: May 07, 2022

Accepted: August 18, 2022

Published online: October 19, 2022



## Introduction

In today's world, women's safety is one of the most essential concerns, and harassment is prevalent and on the rise in almost every country. Rape cases in India have increased by more than two-thirds since 2013, according to the smart IoT devices. Having a high number of reported incidents indicates a lack of predictability, and women feel less secure because of a variety of factors related to their safety. Women's safety has grown to be a major concern as a consequence of an increase in crimes against women. Every day, women confront many difficulties, necessitating the creation of a system to guarantee their safety. This study focuses on such a situation and offers an alternative answer to the problems that women encounter on a daily basis. Smart Wearable Device (SWD) is presented in this study, which is related to the Internet of Things (IoT), a piezo buzzer, a GPS sensor, a push-button, and Machine Learning Strategies. This women's electronic framework demonstrates a nearly secure situation. One of the most significant advantages of this gadget is that it adjusts the real-time dataset obtained from a variety of sources, including a social media dataset and live recordings from a smart device. Women might feel more comfortable knowing that they have an extra ally in the form of this Smart Device.

Although there are several present security frameworks, the need for a more sophisticated smart security framework is increasing every day. Smart security architecture for women has been created to solve these issues. There are several studies in the literature on women's safety measures, but they are all hampered by issues like high costs, a narrow scope of coverage, inaccuracies, and a disproportionately high time commitment. Modern technology and machine learning help were used to construct this piece. This was a natural outcome. You don't need anyone else's support or reliance when you use this gadget for women and children. When using the MLSTF, which stands for Machine Learning, based Social Threatening Filter, all of the dataset's emotional characteristics are filtered out while

processing is taking place. As a result, the data processing leads to an intelligent testing phase with the appropriate accuracy standards.

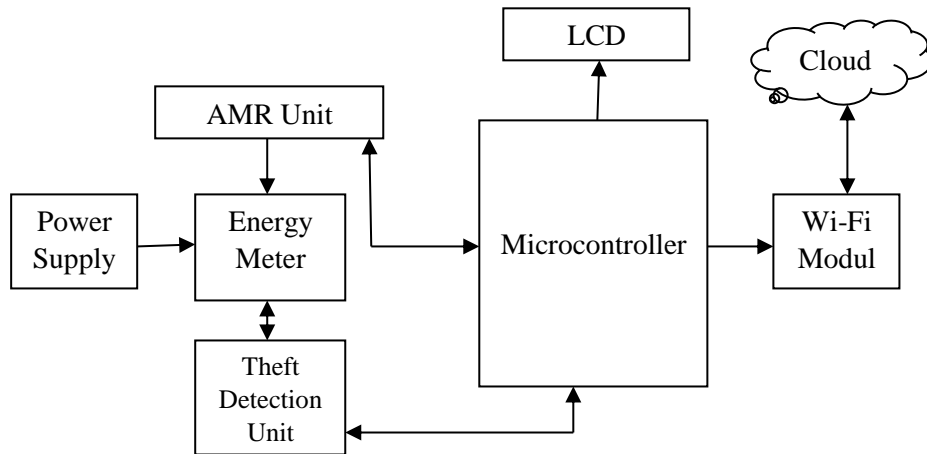

Figure 1. Block Diagram of IoT based System

In order to record emergency speech recordings, the gadget is equipped with sensors such as a Body Position Identification Sensor, a Refers To the capability Sensor, an Accidents Recognition Sensor, a Small Mic, and a pen-hole camera as shown in fig 1. With the support of internet services and wireless connections, these partnerships enable the smart gadget to operate flawlessly. When a lady is in danger, she may simply reach the smart device's button and request assistance. When the emergency button is pushed, notifications are sent to pre-registered contacts as well as women's hotline numbers. A GPS sensor is also used to transmit the position. A link to the victim's current location will be sent to the recipient. The attacker may shut the victim's mouth and prevent her from requesting assistance. The speaker on this gadget generates high-frequency sound. It will raise the alarm in the surrounding area and make the attacker fearful.

#### A. Sentiment Analysis

One of the most essential concerns for women's safety systems is Sentiment Analysis, in which data from social media is gathered and processed using the presented technique MLSTF categorization concept based on emotive elements. For example, this view may be used to create a sentiment which can then be used to categorise sentiment. We need to determine what sorts of needs are derived from the subject's feelings. If the user wishes to classify tweets based on their content, he or she will need to employ a computer formula. The size of the sentimental class is a critical factor in determining the algorithm's efficacy. Class module sentiment classifications of tweets may be divided into Positive, Negative, and Moderate, for example. Based on machine learning and dialect learning, sentiment analysis techniques may be divided into two basic categories: A machine learning strategy is used to extract features and train models using a collection of features. In contrast, the dialect learning

method makes use of the same language and scoring system to discover differences of opinion. In this study, we make use of artificial intelligence. Data collection, pre-processing, feature extraction, feature selection, emotion detection, and emotion classification are the fundamental phases in emotional analysis. Machine learning methods or simple calculations may be used to accomplish these tasks. This picture, Fig-2, depicts the data analysis process in a straightforward and concise way, with each step clearly labeled and shown.

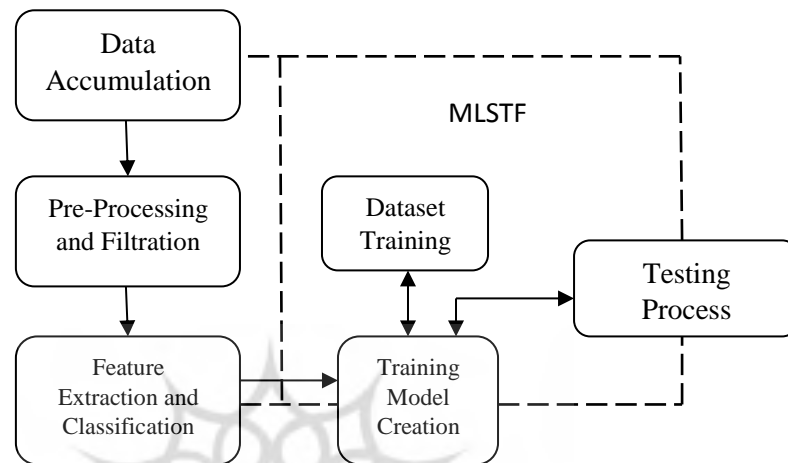

Figure .2 Data Analysis using MLSTF's Proposed Approach

### B. Location Detection Process

The main difficulty in dealing with such circumstances is the location identification, which is addressed by the suggested technique by providing a Smart Wearable Device (SWD). With the help of the Global Positioning System (GPS), this SWD can offer precise longitude and latitude coordinates. A person's whereabouts may be tracked with this technology, as can the location of an item. GPS will transmit a message including the location's current state, time, longitude, and latitude. In order to precisely find the present location of a device, GPS first establishes a connection with the requisite number of satellites and then starts a procedure that solves linear equations. In reality, the GPS doesn't actually need consumers to send data; it works independently on the internet to enhance GPS positioning. This GPS feature is accessible as a module for any mobility device, enabling women to monitor their whereabouts in potentially dangerous situations. The GPS position data is immediately sent to the IoT server. During a certain amount of time, location information is uploaded into the server with a summary of each location. In the event of an emergency, it is simple to locate the ladies based on this information.

### C. Smart Wearable Device

Using a Smart Wearable Device, the suggested method presents a novel mechanism for protecting women against harassment and associated risks (SWD). To assess emergency scenarios and transfer those facts to the Internet of Things modules for monitoring and

maintenance, this SWD comprises a number of unique sensors and an Artificial Intelligence process. Remotely, machine learning processes are engaged and filter data depending on the emergency circumstances or regular situations; if any instance of emergency occurs, the relevant personnel will be contacted with location information and a snapshot of the current situation. As a result, the individual may move quickly to save the ladies in an unharmed way. The Smart Wearable Device (SWD) combines all of these features into one convenient package for ladies. SWD-bound sensors include the Body Position Identification Sensor, the Place Sensor, the Accident Detection Sensor, the Small Mic, which recognizes emergency speech and acts as a black box, and the Penhole Camera, which captures a picture of the appropriate location. The Body Posture Identification Sensor is utilized to determine whether the female subject is in an upright or a felt-down position. The GPS module offers a thorough report of the women's current position, including their latitude and longitude, so investigators may pinpoint their precise location. If an accident occurs, the Accident Detection Sensor will quickly detect it based on the vibration level and send an alert to the right person so that they may take proper action. A pen-hole camera and a small microphone are utilized to record audio and images of the present scenario, which are then sent to the IoT server for processing. So, the SWD is able to execute at a high level because of these factors.

## Literature Review

(Kumar V et al., 2022) With the use of sensors, data processing, and alarm messages sent to the authorities, this system helps keep women safe and even saves their lives in emergency situations. The suggested model has been built and is suitable for use in a live surveillance system for women's safety. In the future, IoT-based technologies will be employed in various fields, such as healthcare, military, monitoring, and pilotless aircraft.

(Hemasagar K et al., 2022) It has a GPS tracker that allows us to know where the victims is at any given moment. Security alerts are sent to a neighboring police department and a list of pre-saved contacts through a GSM module. In the range of 80–110 dB, the buzzer system may be heard from a distance of 50 feet. Further research may be done using the device's built-in cameras.

(Satapathy S et al., 2022) An integrating gadget for measuring psychological stress might be developed based on the results of this study, which aimed to determine the stress levels of 200 farm employees based on measurements of two related parameters (BPL and BT) while they were engaged in agricultural activity.

(Strengers Y et al., 2022) To summarise, we've come to the conclusion that existing energy paradigms need to be reexamined in light of the rapid and ongoing transformations in our day-to-day lives brought on by the internet age. As part of business discussions and

demonstrations, as well as speculation investigations in ethnographic fieldwork and in research or teaching, we lay out our goals further to investigate the future possibilities.

(Sankara Babu B et al., 2022) Machine learning approaches for gait analysis are the focus of this article, which aims to familiarise readers with the most common methods of implementation. Following a quick examination of the most important human gait metrics, a comprehensive look at the state-of-the-art in machine learning for human gait analysis is provided.

(Usharani S et al., 2022) Anakonda and Keras are used to mimic the wrist band architecture suggested in this paper. According to the test findings, when IoT devices are used in conjunction with deep learning methodologies, the produced results are better in terms of accuracy and precision. As soon as a departure is identified from the usual range, an alert will be sent to the user, who may then share the results with their caregivers for diagnostics.

(Goetz C et al., 2022) Researchers employed biometrics and Support Vector Machine (SVM) as the key data extractors to tackle stress, which was identified as the industry's most common mental health concern. Furthermore, the accuracy of individual situations was increased by the use of information fusion approaches. However, the interest in mental health care has only recently evolved, and a number of hurdles must be overcome before systems can be implemented in real-world contexts.

(Rastogi R et al., 2022) By analyzing microstructures & categorizing us into a deep neural network (DNN) utilizing a ML architecture, the research was undertaken. There are risks associated with employing deep hidden neural nets in tissues microscopic pictures Deep neural networks are only used for categorization (photo search) based on the main picture (e.g., displayed name) and similarity in neural networks deep .

(Liu X et al., 2022) We present a lightweight smart IoT devices model for wearable device gait identification to solve the issue of excessive computational complexity in current approaches.

(Mahesh T R et al., 2022) With the suggested technique, accuracy is ensured by increases in overall performance, such as the accuracy of information collection, a lower error rate during processing, a lower time complexities, as well as requirement and responses counts. According to the MLSTF's recommended method, women who are subjected to mistreatment may be protected in an intelligent way, and the resultant section ensures accuracy levels in an effective manner.

(Kumar V A et al., 2021) This study is unique in that it aims to warn doctors about the heavy bleeding that might occur after delivery in pregnancies. To keep mothers safe from the PPH, we're developing an automated solution based on wearable technology. Temperature,

pulse, blood pressure, and perspiration rate are all monitored by these gadgets in pregnancies. In order to assess the effectiveness of the proposed model in lowering mortality and morbidity, fuzzy neural technique-based rules are applied to each statistic.

(Rumiantcev M, 2021, pp 381-389) As part of this study, we developed an experimental recognition system that makes use of sensor data and machine learning methods. It's designed to figure out what people are thinking and feeling. Personal security and healthcare are only a few possible uses for these kinds of detection techniques.

(Raghunath, K. M. Karthick, 2022) The authors have proposed an IoT-based monitoring and control system for pregnant women that collects data at a cloud server to reduce risk during pregnancies in rural places (where women cannot contact physicians in metropolitan areas for thorough checks). When it comes to figuring out why so many newborns are dying during their first trimester, machine learning methods will be used.

(Karthick Raghunath, K et al., 2022) There is an urgent need to improve conditions for children's safety and security in our day. It's impossible for youngsters to take care of themselves at this age. We can't always keep an eye on the kids at school, at the playground, or in the neighborhood. A kid safety device based on the Internet of Things is discussed in this study. In order to ensure the safety of the kid, this gadget allows the parent to find and observe the child's surroundings. The temperature and movement of the infant may be monitored using this gadget. A text message is automatically sent as an SMS to the parent if an issue continues.

(Meraj M et al., 2021) The Internet of Things (IoT) is being used by researchers to gather real-time sensory data for the identification and prediction of infectious diseases. One of the primary focuses of this study is the implementation of a system of sensors across the workplace for the purpose of monitoring for signs of infectious disease. In the cloud storage unit, real-time data may be collected by sensors, and the user must be informed of the real-world situation of the data suggested. This filtering and analytics procedure is used to perform operations on the collected data and to extract user information.

(Vinoth Kumar V et al., 2021) With little capital expenditures, green technology may be used to achieve the sustainable development goals, according to the author's proposal in this section. In addition, the author covers a wide range of connected subjects and technologies, giving the reader a comprehensive understanding of the new concept's possibilities.

(Chougula B et al., 2014) In order to find an approximation explicit solution to a phase change issue with a non-uniform starting temperature distribution, the Homotopy Perturbation Method is modified in this article. Homotopy perturbation method's initial initial approximations have been selected to satisfy the moving boundary value problem's beginning and boundary requirements.

(Pantelopoulos A & Bourbakis N G, 2009) In order to determine how far wearable health-monitoring systems have come in terms of maturity, a collection of key elements, which best reflect the system's functioning and attributes, have been identified. Not to condemn, but to serve as a guide for those working in the field and provide a direction for their work in the future.

(Shalini A, 2018) An important part of suraksha's concept is to flash a warning to the police so that they can quickly locate the distressed victim and bring the perpetrator to justice. This would help decrease the number of women being raped. Suraksha gadget is explored in further length in this publication as well as a summary of other major research in the subject.

(Nalajala P & Godavarthi B, 2017) The GPS/GPRS/GSM SIM900A is used in this system. The vehicle's current position is determined by GPS, the tracking data is sent to the server through GPRS, and an alarm message is sent to the owner's mobile phone via GSM. In order to identify the car's location on the website, this technology is installed inside the vehicle and is monitored in real-time.

(Kumar, V.V et al., 2021) Women's self-defense in circumstances such as rape and attacks may be improved by employing GPS systems and android cellphones, according to this article. There will be no longer any need to carry valuables about with you when you use our suggested system, which will allow you to protect yourself and your possessions from harm at an extremely low cost.

(Wadhawane A et al., 2017) As a consequence of this endeavour, the mesh network has received some comments. In unicast mode, a node may communicate with other peers. While in broadcast mode, a node may communicate with all other nodes in the same personal area network. There must be at least one broadcast node in a mesh network, and the DL address of all the other nodes must be identical to MY. Without it, it is not possible to build a mesh network.

## **Proposed Model**

The suggested solution presents a novel mechanism to safeguard women from harassment and other associated risks, which is accomplished via the use of a Smart Wearable Device (SWD) (SWD). A number of novel sensors and an Artificial Intelligence process are integrated into this SWD, which analyses emergency scenarios and passes those facts to IoT modules, for monitoring and maintenance, which collects data and sends it to the relevant cloud server. Data is filtered depending on an emergency or normal circumstances by a remote server-side machine learning process. In the case of an emergency, relevant persons are quickly contacted with location information and a snapshot of the present situation. In order for the individual to be able to act quickly and safely to rescue the ladies. Women will find the Smart Wearable



Device (SWD) to be a useful companion since it combines all of these features in one convenient package. The following is a complete list of SWD's sensors: Spot sensor, accident detection sensor, small mic for detecting the emergency voice and pen hole camera for photographing the particular location are all included in this kit. Depending on the x and y-axis conceptions, the Body Posture Identification Sensor is employed to determine if the particular woman is in a straight position, felt-down, or subjected to any other limitations. The GPS module, which uses the Global Positioning System (GPS) to determine the women's current position, delivers a complete report of their current location, including their precise latitude and longitude. In the event of a collision, this sensor is utilized to identify the female victims. Whenever an accident occurs, this sensor detects it and provides an alarm to the relevant people so that they may take the required precautions to avoid additional harm. A small microphone too a pen-hole camera are utilized to record the speech & accompanying images of the present scenario, which are then transmitted to an Internet of Things-enabled distant server for processing. As a result of all of this, the SWD is able to operate in an efficient way.

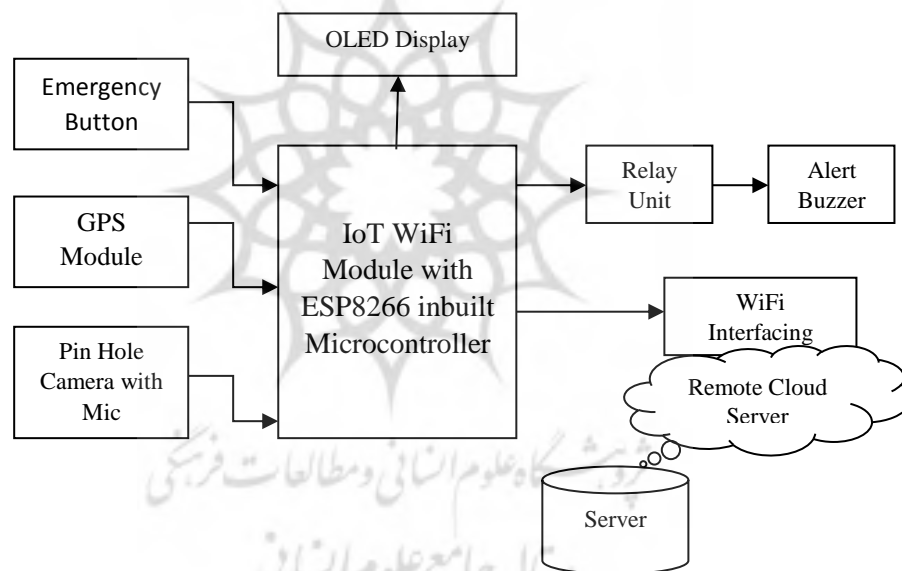

Figure 3. Transmitter Section

The suggested logic is comprised of two important components: a machine learning-based data summarization model for assuring women's safety upgrades. Combining these two approaches results in a brand-new technique, the Machine Learning-based Social Threatening Filter (MLSTF). The MLSTF logic uses emotive estimates to extract dataset attributes in this technique, and any incorrect perceptions discovered are immediately communicated back to the relevant individuals so that they can respond appropriately. To illustrate how this logic is activated by an Internet of Things (IoT) equipped microcontroller in compliance with the ESP specifications, below is a simple master block diagram. The transmitter component of the suggested technique is shown in a master block diagram as shown in fig 3, and a novel microcontroller is used in combination with IoT Web interface in this research. Cost-effective

internet services may now be made available through the IoTWeb interface in combination with bespoke mobile apps in conjunction with networked GPS and GSM capabilities. The IoT module can swiftly establish a person's position and provide that information to them through GSM messaging services utilizing these connections. The following graphic shows suitable block designs and display units, with the OLED display being used in this SWD instead of any such long LCD displays.

Fig. 4 shows the receiver unit block diagram, with each input from the remote server being extensively investigated by the machine learning process that permitted server-end scripting. The related results are kept in the server end, and the corresponding results are shown in the output with the necessary metric information. A smart phone, tablet, PC/laptop, or other smart gadget may be used to easily see the resulting summary.

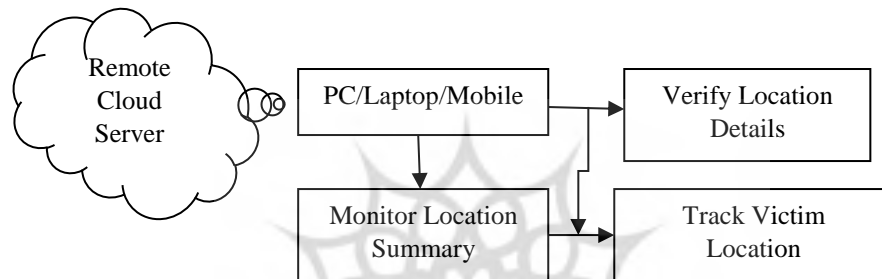

Figure 4. Receiver Section

The data from the Smart Wearable Device is gathered and delivered to a remote server through the Internet of Things module, while the OLED display shows the relevant result at the client end. Once the server end has acquired the information, the receiving end may simply watch it without the requirement for a specified range or time limit. (Figure 5)

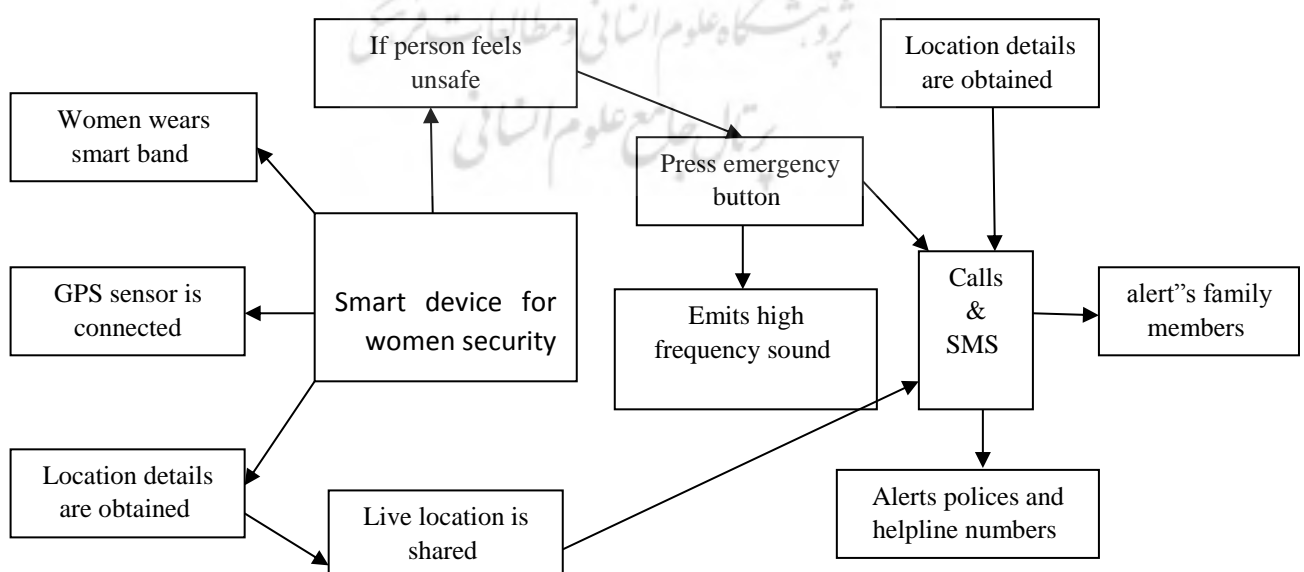

Figure 5. System model

## A. Hardware connections

This project made use of a Bolt Wi-Fi Module v2, a GPS sensor, a 10K Ohm resistor, a push button switch, connecting wires (male to female), a Nano Breadboard, a Piezo Buzzer, and a 5V micro-USB power converter, among other components.

- i. Connections between the GPS sensor and the bolt:
  1. Pins 1 and 2 are used to link the TX and RX signals.
  2. Connecting the GPS sensor's GND (ground) to the GND of the Bolt module. (There is just one GND pin available in the Bolt module.) We are supplying a common ground via the use of a breadboard in order to make GND accessible to other components.
- ii. Connections between the speaker and the bolt
  3. The breadboard connects the negative pin to GND.
  4. Pin 4 of the Bolt module is linked to the positive pin.
- iii. Push button to bolt connections
  5. There is no positive or negative for a push button switch.
  6. One pin is linked to GND via a breadboard, while the other is attached to Bolt module pin 0

Setting up the wifi module for the bolt is the first step
- iv. Install the Bolt app.
- v. Set up an account
- vi. Adding Bolt to your account.
  7. The blue Driven will start to squint and the green Driven will turn off as soon as you switch on the Jolt gadget.
  8. You'll know your Jolt is ready to be set up when the blue Driven squints slowly, indicating that it has sent its unique Wi-Fi 33 hotspot settings to your phone.
  9. Jolt must be linked to a Wi-Fi 33 network. By tapping the Wi-Fi 33 title, you may connect to the Wi-Fi 33 network of your choice.

## B. Twilio APIs

Become a member of twilio.com and enter your phone number to verify it. Visit the Phone Numbers page as much as you want once you've signed up for a free trial account. Check the phone number we've picked for you and note the features it offers, such as voice and text messaging (SMS) and multi-media messaging (MMS). Your route number should be capable of receiving and sending SMS messages, as well as receiving calls from non-local phone numbers. On the phone numbers page, you'll be able to examine the capabilities of

your phone number at your leisure. From the Twilio dashboard, get your authentication id and account sid.

### Programming in Python

1. bolt.iot, json, time and pymysql should be imported.
2. access the database and extract data from it
3. True, however:

The pin 0 digital read may be read (push button)

In an emergency situation, press the emergency button:

- ζ Share your location with loved ones  
a piezo buzzer is used to notify

### C. Energy - efficiency Model

To assure the dependability of the connection, it may be required to transmit data many times, which accounts for a bigger part of the whole energy usage because of the extra propagation loss. Thus, the energy consumed to send the 1-bits message ( $E_{tx}$ ) and to receive this message ( $E_{rx}$ ) is, respectively.

$$E_{tx} = l \cdot E_{elec} + \frac{l}{R} \cdot P_t \quad (1)$$

$$E_{rx} = l \cdot E_{elec} \quad (2)$$

Let  $A$  be the circumference of the cylindrical flank and let  $I_t$  represent the current intensity, then the transmitted power may be expressed as follows:

$$P_t = A \cdot I_t = 2\pi r \cdot H \cdot I_t \quad (3)$$

where  $I = p^2/\rho c$  [23], and  $\rho c$  is the acoustic impedance. Let  $SL$  signify the source level, the original  $I_t$  may be represented as the sum of the sensitivity of the sensor level and the average intensity:

$$I_t = 10^{SL/10} \cdot \frac{p^2}{\rho c} \quad (4)$$

For the absorption loss in the medium,  $(f)$  refers to Thorpe's equation. The transmitted power ( $P_t$ ) may be expressed in terms of Equations (3).

$$P_t = C_h \cdot H \cdot r \cdot e^{\alpha(f) \cdot r} \quad (5)$$

Where

$$C_h = 2\pi \times 0.67 \times 10^{0.1(\text{SNR}+\text{NL})-18} \quad (6)$$

$$\tilde{\alpha}(f) = \alpha(f) \times 10^{-4} \times \ln 10 \quad (7)$$

#### D. Proposed Algorithm

---

##### Algorithm 1

---

1. Begin
  2. Input the IoT based System
  3. Read the collected data V, I, and P from sensors
  4. Register internet aided web server and display data
  5. Register internet aided Blynk mobile application and display data
  6. Display data in the LCD module
  7. If P is greater than the set limit value, Then
  8. Relay is activated
  9. Else
  10. Relay is deactivated
  11. End if
  12. End
- 

## Results and Discussion

When the button is pressed, the device emits a high-pitched sound and sends out text messages, phone calls, and sends out notifications to the user's family and authorities. Figure 6 shows the suggested Smart Wearable Device's internal hardware unit design viewpoint, which comprises the IoTWeb module and the proper power supply links.

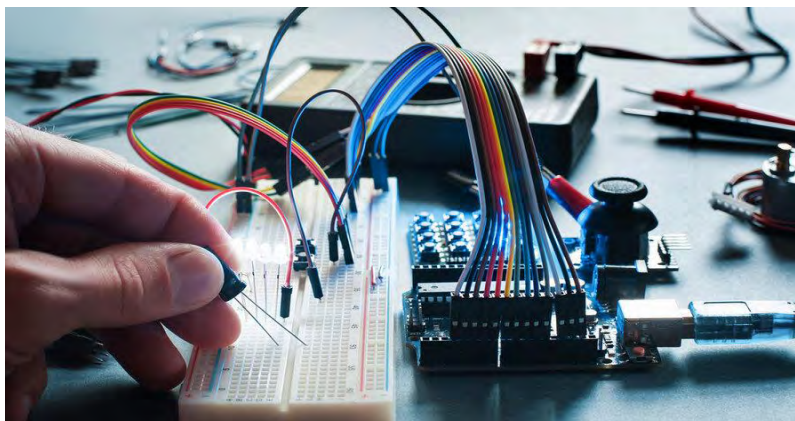

Figure 6. Hardware design

Figure 7 (a) depicts a view of the proposed Smart Wearable Device's internal hardware unit, which includes the IoTWeb module and the relevant power supply connections. The gizmo runs on less than 5 volts direct electricity, which is all it takes to keep it going for 5 to 6 hours. Detailing the dimensions of the SWD's interior perspective is shown in more depth in the related picture, Fig-7 (b).

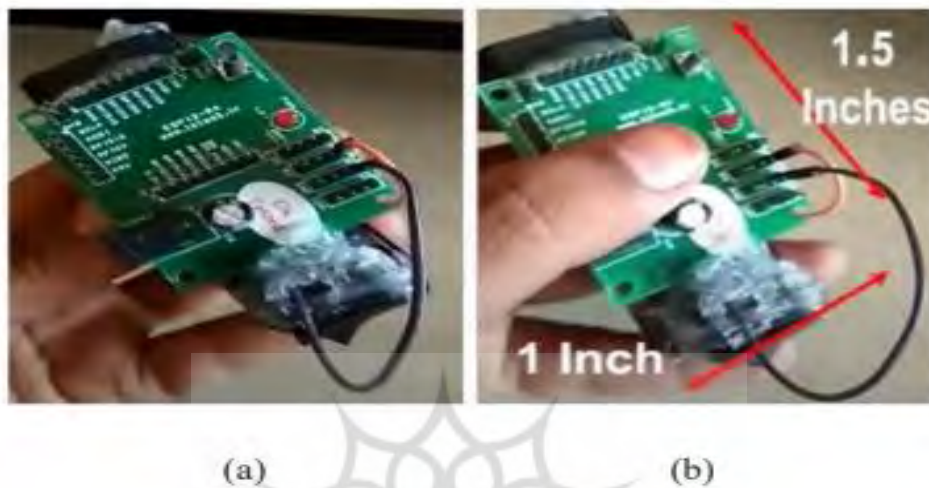

Figure 7. (a) Internal Hardware Section of SWD and (b) SWD Dimension Specifications

Web page:

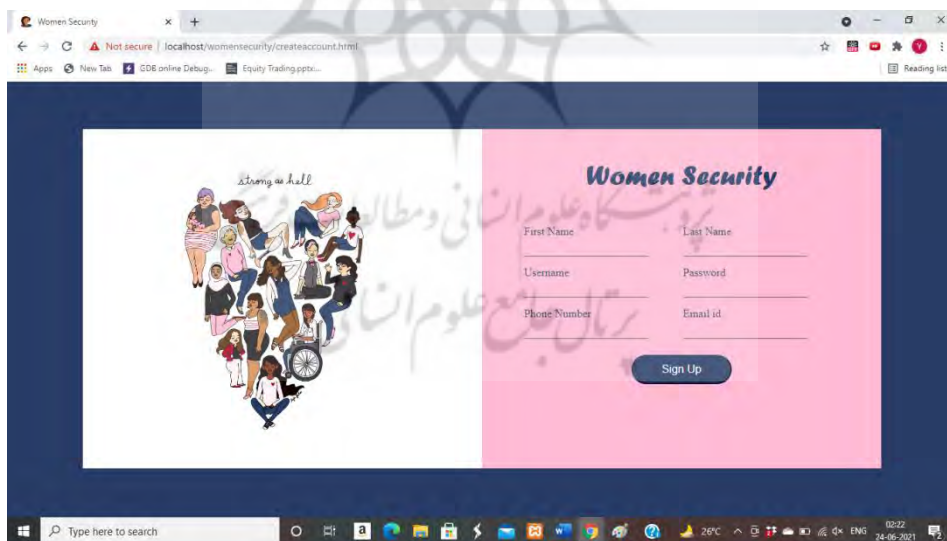

Figure 8. The web page login representation.

The login page, signup page, profile information page, contact information page, edit contact, edit profile, and reach page are all shown in Fig-8, which depicts the web page's structure.

This technique is shown in the accompanying image, Fig-9, which shows how the Smart Wearable Device aggregates the data from the sensor units and sends them to a distant server in a fraction of a second, demonstrating how time constraint efficiency is achieved. However, this process is ongoing and occurs at regular intervals; the accompanying, illustrates the time estimate details for assessing the number of details acquired from the SWD in milliseconds and the number of data accumulated in the server end based on the time parameters.

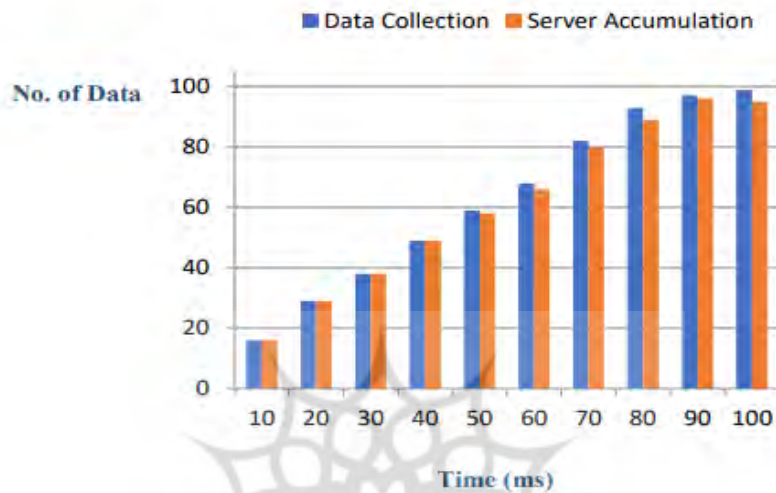

Figure 9. Data Collection and Server-Side Data Accumulation Ratio Estimation Perception based on Time Concern

Alert mechanism accuracy level estimates may be seen in this image 10, which clearly shows the number of messages triggered by Smart Wearable Device and the number of messages delivered to the receiver. Data processed from SWD and the number of alarms triggered and messages delivered to the recipient are shown on the x and y axes, respectively.

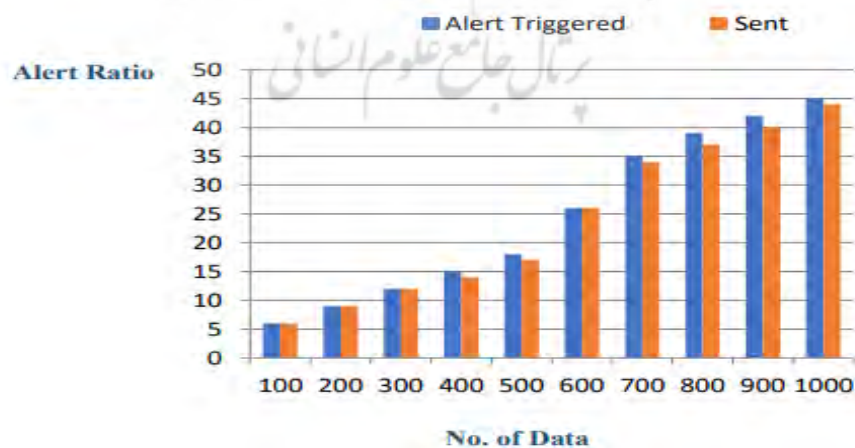

Figure 10. No. of Alerts Triggered vs. No. of Alerts Sent

## Conclusion

Currently, the safety of women is a major concern all around the globe. Women's criminality is on the rise in India, particularly on an hourly basis. With the help of Internet-of-things (IoT) software, ladies will be helped in tough circumstances. There are various new technologies in this article, including the Internet of Things, piezo buzzer and GPS sensor. The Smart Wearable Equipment (SWD) is a smart women's safety device that incorporates these technologies, as well as machine learning strategies. This electronic framework for women shows an almost secure. One of the most significant advantages of this gadget is that it adjusts the real-time dataset obtained from a variety of sources, including a social media dataset and live recordings from a smart device. Women might feel more comfortable knowing that they have an extra ally in the form of this Smart Device. As a result, when the emergency button is pushed, the suggested system would transmit the user's current position through text messages, make automatic calls to family and authorities, and emit a high frequency signal. This initiative assists women who are in difficult situations. It aids in the notification of friends, family, and authorities. It also generates high-frequency sound in order to make the attacker fearful and seek assistance from surrounding individuals. The project includes a web page that allows users to quickly view and update their personal information.

The suggested technique may be further developed by using certain deep learning processes to improve accuracy and scalability, which is another consideration to keep in mind. With these enhancements, the finest possible system for women's safety will be even better.

## Conflict of interest

The authors declare no potential conflict of interest regarding the publication of this work. In addition, the ethical issues including plagiarism, informed consent, misconduct, data fabrication and, or falsification, double publication and, or submission, and redundancy have been completely witnessed by the authors.

## Funding

The author(s) received no financial support for the research, authorship, and/or publication of this article

## References

- Bhardwaj, N., & Aggarwal, N. (2014). Design and Development of "Suraksha"-A Women Safety Device. *International Journal of Information & Computational Technology*, 4(8), 787-792.
- Chougula, B., Naik, A., Monu, M., Patil, P., & Das, P. (2014). Smart girls security system. *International Journal of Application or Innovation in Engineering & Management*, 3(4).
- Gadhe, S. B., Chinchansure, G., Kumar, A., & Ojha, M. (2015). Women Anti-Rape Belt. *Compusoft*, 4(4), 1632.



- Goetz, C., Bavaresco, R., Kunst, R., & Barbosa, J. (2022). Industrial intelligence in the care of workers' mental health: A review of status and challenges. *International Journal of Industrial Ergonomics*, 87, 103234.
- Hemasagar, K., Manoj Kumar, R., Sai Manojna, V., & Priya, B. K. (2022). Ingenious Bracelet for Women Safety and Security Using IoT. In *Emerging Research in Computing, Information, Communication and Applications* (pp. 253-265). Springer, Singapore.
- Karthick Raghunath, K. M., Koti, M. S., Sivakami, R., Vinoth Kumar, V., NagaJyothi, G., & Muthukumaran, V. (2022). Utilization of IoT-assisted computational strategies in wireless sensor networks for smart infrastructure management. *International Journal of System Assurance Engineering and Management*. doi:10.1007/s13198-021-01585-y
- Kumar, V. V., Muthukumaran, V., Ashwini, N., Beschi, I., Gunasekaran, K., & Niveditha, V. (2022). An Efficient Signcryption Scheme Using Near-Ring Hybrid Approach for an IoT-Based System. *International Journal of e-Collaboration (IJeC)*, 18(1), 1-31. <http://doi.org/10.4018/IJeC.299011>
- Kumar, V.V., Raghunath, K.M.K., Muthukumaran, V. (2021). Aspect based sentiment analysis and smart classification in uncertain feedback pool. *Int J Syst Assur Eng Manag*. <https://doi.org/10.1007/s13198-021-01379-2>
- Liu, X., Chen, M., Liang, T., Lou, C., Wang, H., & Liu, X. (2022). A lightweight double-channel depthwise separable convolutional neural network for multimodal fusion gait recognition. *Mathematical Biosciences and Engineering*, 19(2), 1195-1212.
- Mahesh, T. R., V. Dhillip Kumar, V. Vinoth Kumar, Junaid Asghar, Oana Geman, G. Arulkumaran, and N. Arun. "AdaBoost Ensemble Methods Using K-Fold Cross Validation for Survivability with the Early Detection of Heart Disease." *Computational Intelligence and Neuroscience* : 1–11. doi:10.1155/2022/9005278
- Meraj, M., Alvi, S. A. M., Quasim, M. T., & Haidar, S. W. (2021, August). A critical review of detection and prediction of infectious disease using IOT sensors. In *2021 second international conference on electronics and sustainable communication systems (ICESC)* (pp. 679-684). IEEE.
- Nalajala, P., & Godavarthi, B. (2017). Working Women Hand Held Safety Self Defense System using IoT. *Journal of Advanced Research in Dynamical and Control Systems*, 9(18), 2051-2059.
- Pantelopoulos, A., & Bourbakis, N. G. (2009). A survey on wearable sensor-based systems for health monitoring and prognosis. *IEEE Transactions on Systems, Man, and Cybernetics, Part C (Applications and Reviews)*, 40(1), 1-12.
- Parasher,t Y., Singh,t P., & Kaur, G. (2019). Green Smart Security System. In *Green and Smart Technologies for Smart Cities* (pp. 165-184). CRC Press.
- Raghunath, K. M. Karthick, V. Vinoth Kumar, Muthukumaran Venkatesan, Krishna Kant Singh, T. R. Mahesh, and Akansha Singh.(2022) "XGBoost Regression Classifier (XRC) Model for Cyber Attack Detection and Classification Using Inception V4." *Journal of Web Engineering* . doi:10.13052/jwe1540-9589.21413
- Rastogi, R., Chaturvedi, D. K., Sagar, S., Tandon, N., & Rastogi, M. (2022). Risk Stratification for Subjects Suffering from Lung Carcinoma: Healthcare 4.0 Approach with Medical Diagnosis Using Computational Intelligence. In *Internet of Things and Its Applications* (pp. 171-193). Springer, Cham.
- Rumiantcev, M. (2021, January). Emotions and Activity Recognition System Using Wearable Device Sensors. In *2021 28th Conference of Open Innovations Association (FRUCT)* (pp. 381-389). IEEE.

- Sankara Babu, B., Nalajala, S., Sarada, K., Muniraju Naidu, V., Yamsani, N., & Saikumar, K. (2022). Machine Learning Based Online Handwritten Telugu Letters Recognition for Different Domains. In *A Fusion of Artificial Intelligence and Internet of Things for Emerging Cyber Systems* (pp. 227-241). Springer, Cham.
- Satapathy, S., Mishra, D., & Realyvásquez Vargas, A. (2022). Measurement and Prediction of Mental Stress Through Innovative Equipment in Agriculture. In *Innovation in Agriculture with IoT and AI* (pp. 53-68). Springer, Cham.
- Shalini A, Jayasuruthi L & Vinoth Kumar V,(2018) “Voice Recognition Robot Control using Android Device” *Journal of Computational and Theoretical Nanoscience*, 15(6-7), pp. 2197-2201
- Strengers, Y., Dahlgren, K., Pink, S., Sadowski, J., & Nicholls, L. (2022). Digital technology and energy imaginaries of future home life: Comic-strip scenarios as a method to disrupt energy industry futures. *Energy Research & Social Science*, 84, 102366.
- Swami Das, M., Govardhan, A., & Vijaya Lakshmi, D. (2022). A Model of Women Security Using IoT. In *ICDSMLA 2020* (pp. 1539-1546). Springer, Singapore.
- Usharani, S., Bala, P. M., Rajmohan, R., Kumar, T. A., & Selvi, S. A. (2022). Pregnancy Women—Smart Care Intelligent Systems: Patient Condition Screening, Visualization and Monitoring with Multimedia Technology. In *Intelligent Interactive Multimedia Systems for e-Healthcare Applications* (pp. 147-169). Springer, Singapore←
- Vinoth Kumar V, Ramamoorthy S, Dhilip Kumar V, Prabu M, Balajee J.M.,(2021) “Design and Evaluation of Wi-Fi Offloading Mechanism in Heterogeneous Network”, *International Journal of e-Collaboration (IJeC)*, IGI Global, 17(1)
- Wadhawane, A., Attar, A., Ghodke, P., & Petkar, P. (2017). IoT based smart system for human safety. *International Journal of Computer Applications*, 179(7)}

---

**Bibliographic information of this paper for citing:**

Srinivas Rao K.; Divakara Rao, D. V.; Patel, I.; Saikumar, K. & Vijendra Babu D. (2023). Automatic Prediction and Identification of Smart Women Safety Wearable Device Using Dc-RFO-IoT. *Journal of Information Technology Management*, 15 (Special Issue), 26-40. <https://doi.org/10.22059/jitm.2022.89410>

---