

پروپوزیشن گاہ علوم انسانی و مطالعات فرہنگی
پرتال جامع علوم انسانی

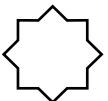

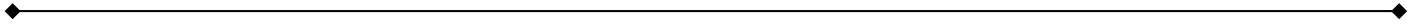

)

(



()

()

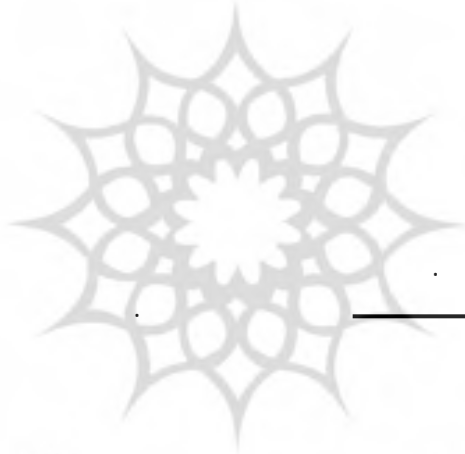

پرویشگاه علوم انسانی و مطالعات فرهنگی
پرتال جامع علوم انسانی

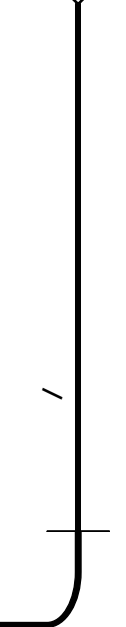

()

()

()

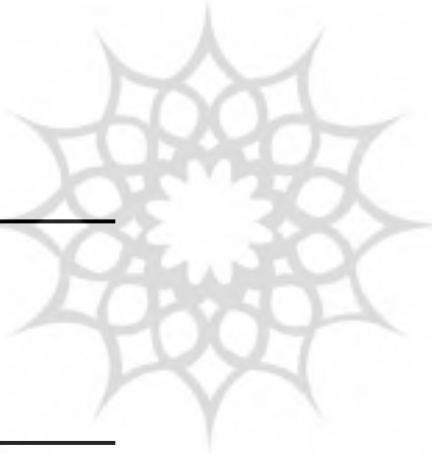

پروپوزیشن گاہ علوم انسانی و مطالعات فرہنگی
پرتال جامع علوم انسانی

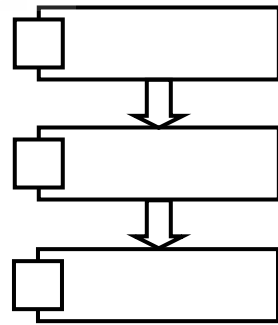

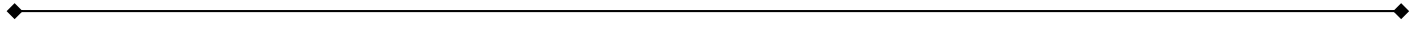

•

)

•

(

•

()

()

•

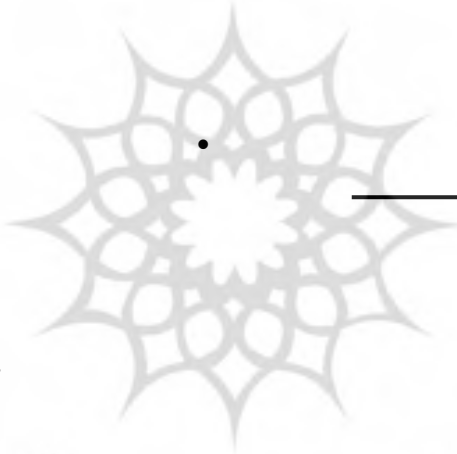

پروہ شگاہ علوم انسانی و مطالعات فرہنگی
پرتال جامع علوم انسانی



•

•

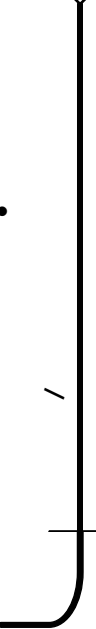
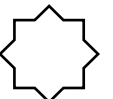

()



پروپوزیشن گاہ علوم انسانی و مطالعات فرہنگی
پرتال جامع علوم انسانی

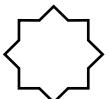

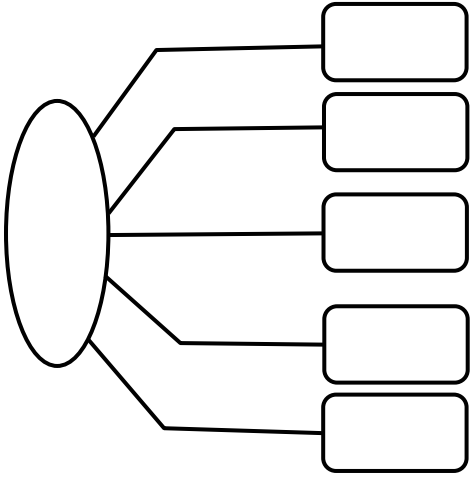

(-)

())

(...

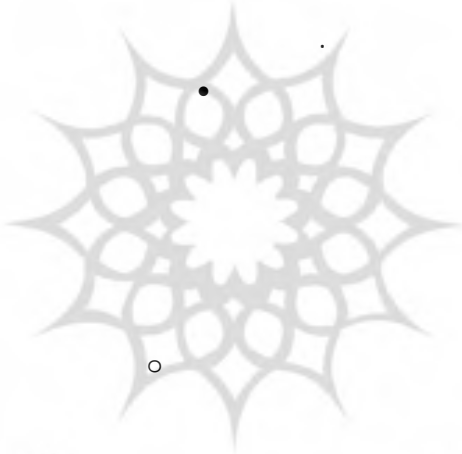

پروپوزیشن گاہ علوم انسانی و مطالعات فرهنگی
پرتال جامع علوم انسانی

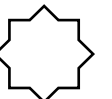

()

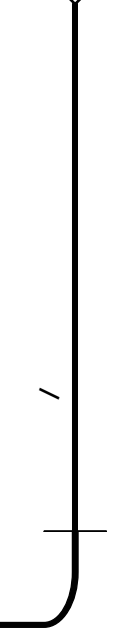

(Industrial SIC

Classification Standard)

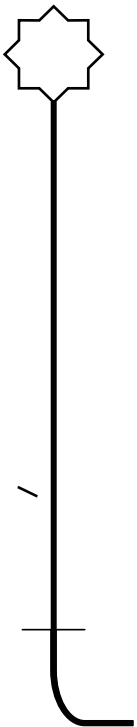

(, ,)

(,)



پروپوزیشن گاہ علوم انسانی و مطالعات فرہنگی
پرتال جامع علوم انسانی

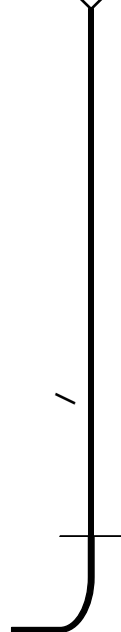
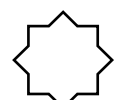

(, ,)

)

(

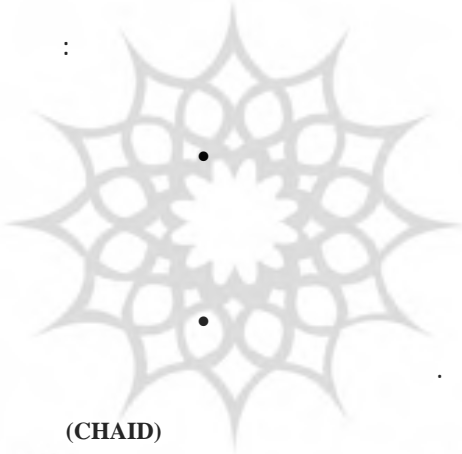

(CHAID)

() شریب شاہ علموں انسانی و مطالعات فرہنگی ()
پرتال جامع علموں انسانی

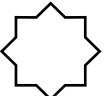

-
3. Sally Dibb and Lyndon Simikin; The Market Segmentation Workbook;1996.
 4. Abram Hawkesplc; Market segmentation : can you really divide and conquer?
 5. <http://www.AbramHawkes.plc>.
 6. Bonoma.T&Shapiro.B,"How to segment industrial markets";Harward business review may-june 1984.
 7. Francois Joseph;Wootin Ian;Market Segmentation;John Wiley & Sons INC;1 st edn 1997.

Wendell smith

Journal of

marketing

2. Malcolm McDonald
3. William L.Wilkie
4. Niche Marketing
5. Sally Dib
6. Linden Simi kin
7. Correspondence analysis
8. Conjoint analysis
9. Artificial Neural Networks
10. Multivariate Logit
11. Multidimensional Scaling



1. William L.Wilkie; Consumer Behavior; 3th edn; John Wiley & Sons INC; 1996.
2. Malcolm Mcdonald and Ian Dunbar; Market Segmentation; Macmillan press LTD; 1 st edn; 1995.