

:

( )

( )

پروپوزیشن گاہ علوم انسانی و مطالعات فرہنگی

( ... )

پرتال جامع علوم انسانی

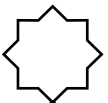



پرویشگاه علوم انسانی و مطالعات فرهنگی  
پرتال جامع علوم انسانی

[ ۱۱ ]

" " " "  
" " " "  
( ) " "

•  
•  
•  
•  
•  
•  
•

•  
•

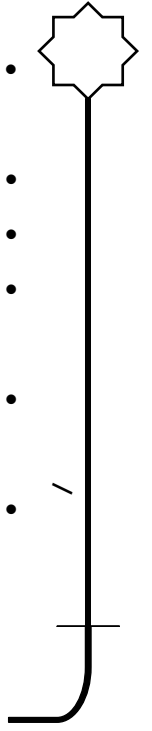



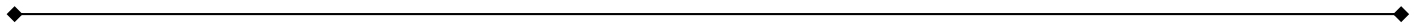

) : •  
(

[ ]

) •  
(

:  
○

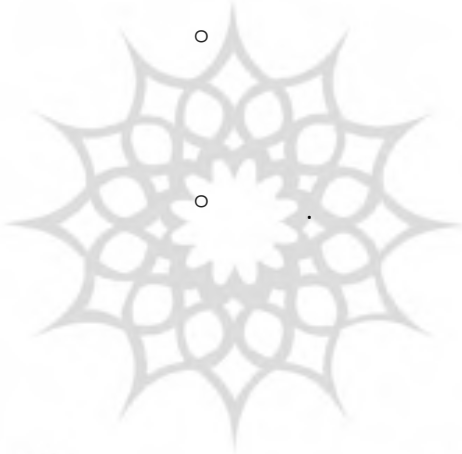

[ ]

پژوهشگاه علوم انسانی و مطالعات فرهنگی  
[ ] [ ] [ ]

) : برتال جامع علوم انسانی  
(

(

" "  
" "



)  
(

[ ]

" "

\_\_\_\_\_

( )

پروپوزیشن گاه علوم انسانی و مطالعات فرهنگی  
پرتال جامع علوم انسانی

: )

\_\_\_\_\_

(...

: [ ]

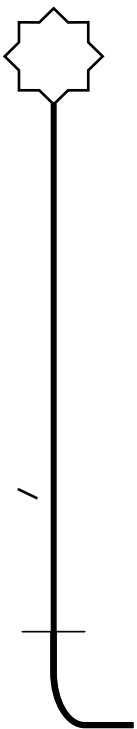

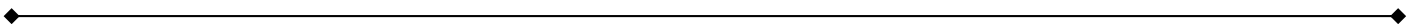

(VE)

(DFT)

(EFQM,FMEA,...)

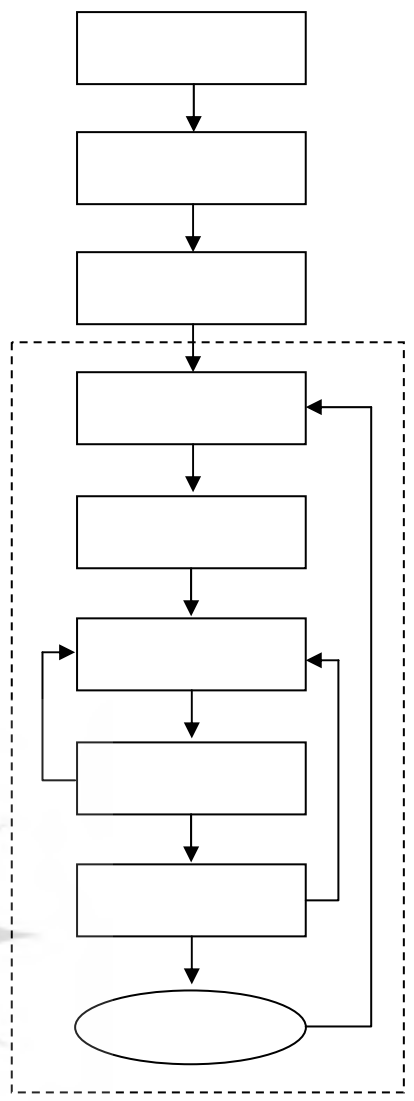

پیشگاه علوم انسانی و مطالعات فرهنگی (TQM)

پرتال جامع علوم انسانی (QFD)

(QCC)

( )

(SS)

(BS)

5S

(PDCA)

( )

(RE)

(TQM)

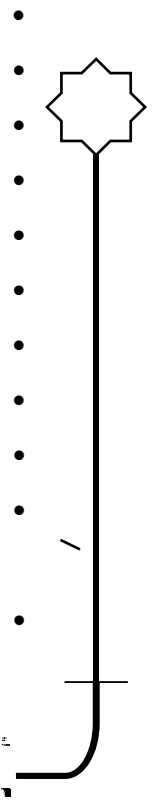



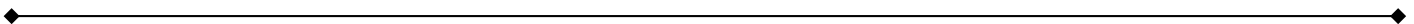

... ( )

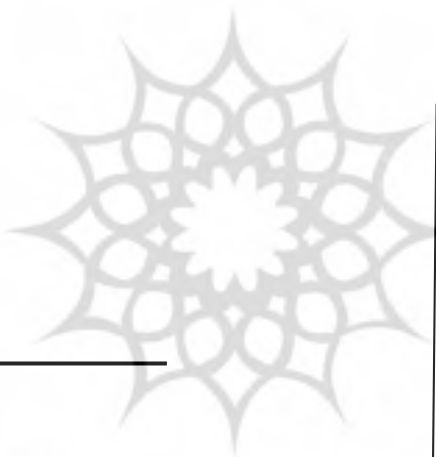

پوهنتون ګاه علوم انساني و مطالعات فرېنجي  
پرتمال جامع علوم انساني

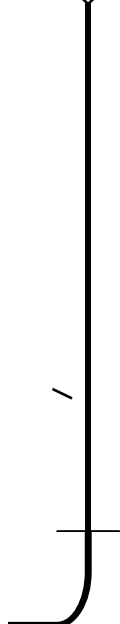
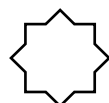
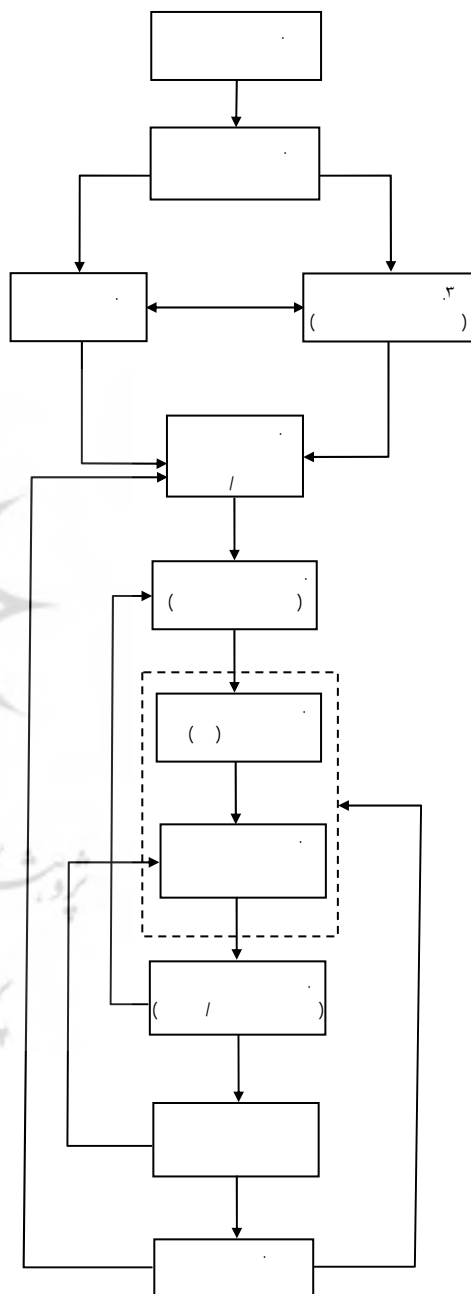



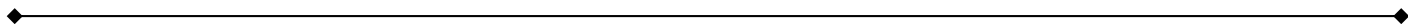

/

:

•

•

(5S)

•

) 5HW

•

(

(PDCA)

•

( )

•

( / )

•

•

( )

•

•

•

•

...

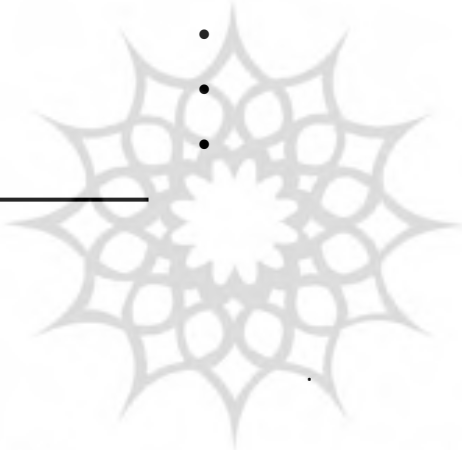

پروپوزیشن گاه علوم انسانی و مطالعات فرهنگی  
پرتال جامع علوم انسانی ( )

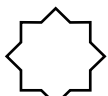

)

(

)

(

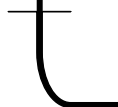

)

(

\_\_\_\_\_

( )

\_\_\_\_\_

( )

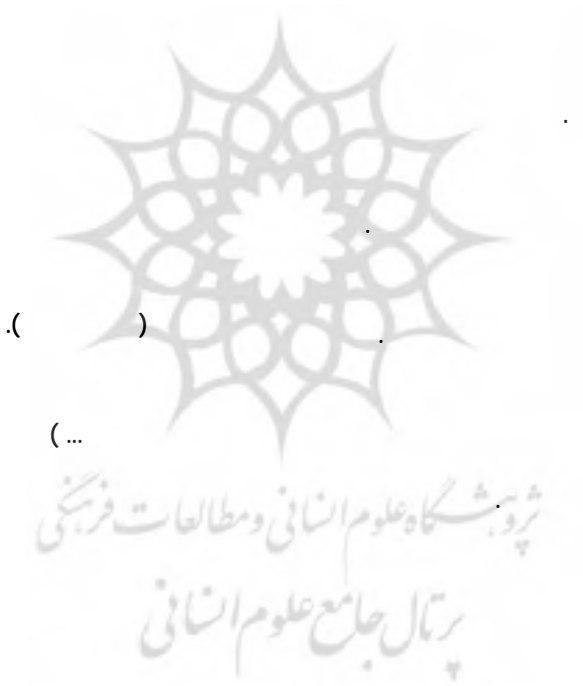

)

( )

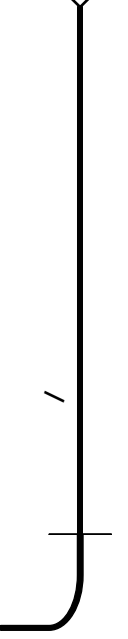
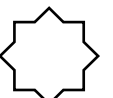

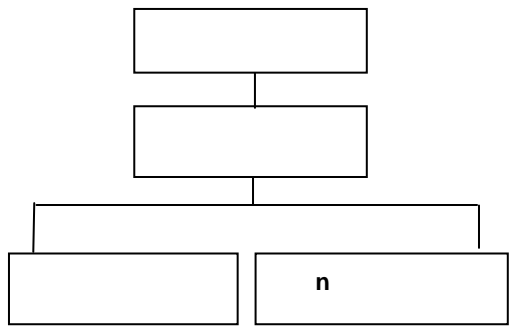

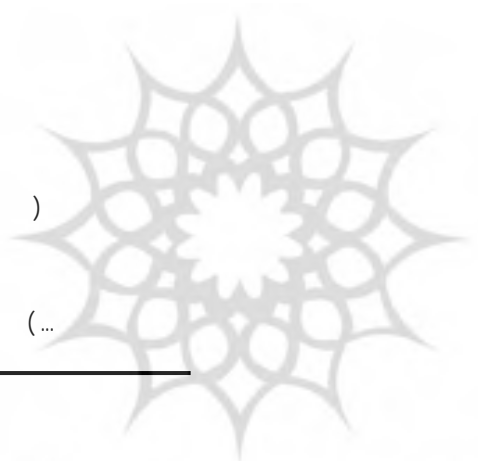

---

( )  
 )  
 (...

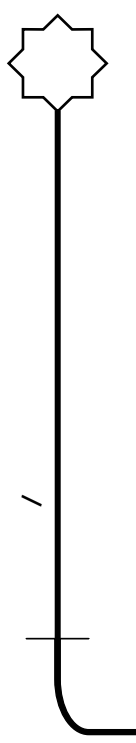

پرویشگاه علوم انسانی و مطالعات فرهنگی  
 پرتال جامع علوم انسانی



- 
- 
- 
- 
- 
- 

- 
- 
- 
- 
- 

- 
- 
-

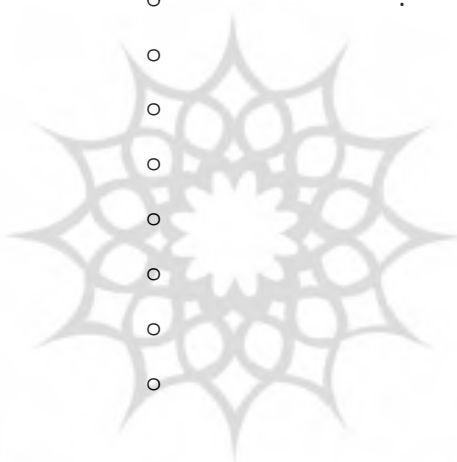

پرویشگاه علوم انسانی و مطالعات فرهنگی  
پرتال جامع علوم انسانی

○  
○  
○  
○  
○  
○

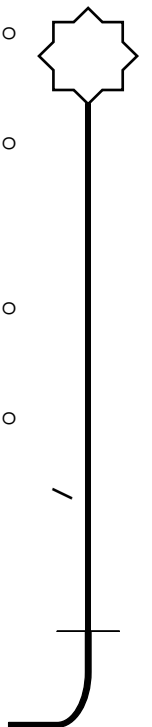

( )

/		/	

( )

( )

( )

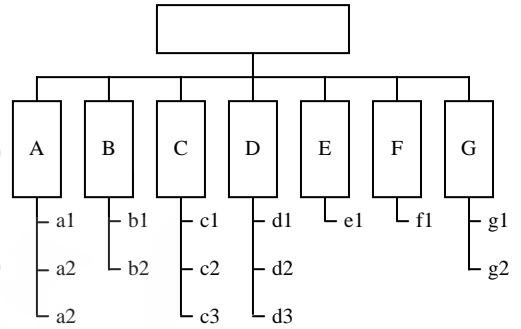

FHD

:

o

o

•

o

•

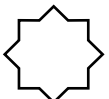

پروپوزیشن گاہ علوم انسانی و مطالعات فرهنگی  
پرتال جامع علوم انسانی

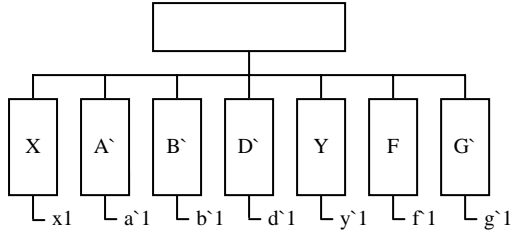

FHD

Y X \*

( A A ) \*

	:	/	
/	/	/	/
			n
		/	

پرویشگاه علوم انسانی و مطالعات فرهنگی  
 پرتال جامع علوم انسانی

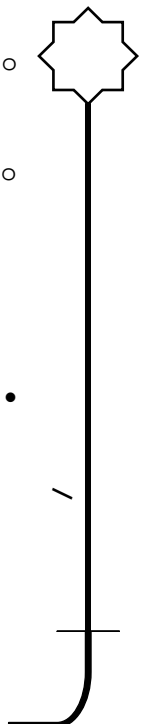



پروہشگاہ علوم انسانی و مطالعات فرہنگی  
پرتال جامع علوم انسانی

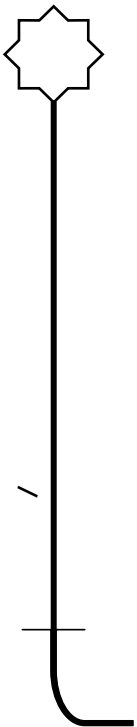

24. lean enterprise ins, **The Psychology of lean**, Canada, 2000
25. M.D.Regan, **The Kaizen Revolution**, 2000
26. K.Sekin, K.Arrai, **TPM for lean factory productivity** press, 1998
27. W.witschey, R.Walf, **Value methodology**, 2000
28. **A Tutorial on poka-yoke**, Association. inc.2000
29. A.Kampocris, **Demand flow Technology**, USA, 2000
30. T.pysdek, **The 6s Revolution**, 2000
31. S.Irane, **value network mapping VNM**, 2002

## QC

)Muda

2. Lean thinking
3. (...Function, Process,...)

7S

Bussiness )

(Activiity Process Function Function Area Area

7. Lean Thinking
8. Muri
9. Noreason
10. Noprinciple
11. Mura
12. Unnatural
13. Inequality
14. Heijo
15. Specifying Value
16. Data Flow
17. Work Flow

12. Kolorik, **creating quality**, MC Grow-hill-1995
13. Mbonvik, **How to control lean manufacturing system**, MIT, 1996
14. Boudin, Michel, **Lean Production**, the end of the management, whack-a-mole-1999
15. James R.Womack, **Lean Thinking, the Lean Enterprise institute**, 1999
16. M.Brion, **An introduction to Agile Manufacturing**, 1998
17. J.Dahlgoord, **TQM and Lean Thinking in higher education**, Denmark, 2000
18. K.Fall, **Mori, Mura, Muda**, 1995
19. J.Womack, D.jonos, **Lean Classics and The Roots of Lean**, 1999
20. B.Swaind and J.martin, **Lean Thinking**, UK. 1999
21. **The Step of lean implementotion**, lean enterprise institute, 2001
22. G.Danilt, S.Mrroy, **Strategic Application of lean thinking**, 2000
23. C.Jones, N.Medlen. **lean, lean enterprise ins**, 1999



پیشرفت علم انسانی و مطالعات فرہنگی  
مجمع علوم انسانی

