

Surveying and Categorizing the Proportion Values of Various Types of Safavid Dynasty's Buildings

¹Homan Khajeh Pour; ²Jamalddin Soheili

¹ Ph.D. Candidate, Department Of Architecture, Faculty Of Art, Architecture & Urban Planning, Najafabad Branch, Islamic Azad University, Najafabad, Isfahan, Iran.

² Assistant Professor, Qazvin Branch, Islamic Azad University, Qazvin, Iran.

Received 11.21.2013; Accepted 09.22.2014

ABSTRACT:

Islamic architecture has been a great influence on different parts of the world, even so there are some similar factors, but the aspect of culture will make the polarization between them. Upon the vast spread that Muslims had in the 7th century (A.D.) Islamic culture and belief moved in different continents from the Far east parts of Asia to the west of the Mediterranean. At the beginning Islam had no specific architecture but with passing of time each and every culture started their own art and architecture and from that beginning Iran was a special primary of this field and of the many dynasties of this country Safavid was one of the highest valued among them all. One of the most important aspects of traditional architecture is their proportion value that holds a great part of the aesthetical valence. The aim of this paper is to know that if there is a common connection within various types of Safavid architecture as a group or individual system. The secondary goal of this study is to see if there is an aesthetic relation between Iranian proportion and European golden ratio. In this study we have surveyed various buildings, in one of the most influence architecture eras of Iranian Islamic architecture and at an end result believe that depending on their functionality the proportion values differ among them.

Keywords: Islamic Architecture, Proportion, Safavid, Isfahan.

INTRODUCTION

Iran has had more than two millennium historical factors that within this time we can discover all aspects of war, hunger, beauty, and art and overall the entire black and white that contains humanity. Upon all of the dynasties that have ruled during this time, the Safavids dynasty is known highly as an age of prospect and rise of art and architecture in this nation.

Islamic architecture heavily depends on engineering and aesthetic principles (Delavar & Saniei, 2011, 431). Iranian architecture in Islamic period gradually turned from symbolism of early century to the much decorations and avoided any realism in the patterns. this rule exclude the buildings or structures which meet material needs and usage such as house of king or castle or places to have fun (Seberi Kakhaki, 2012, 42). It is suggested that Islamic buildings express the religious beliefs, social and economic structure, political motivation and

visual sensibility of a pervasive and unified tradition (Kaptan, 2013, 6). During the Safavids dynasty these aspects had grown to a far and more public view within the cities. The city that was mostly contradicted by this movement of the time was Isfahan. Before people and their governments mostly paid attention to mosques but during the Isfahan movement all aspect of the city were endeavored with importance and structure such as bridges, Official housings and even privet houses.

Closely related to the idea of "Hidden architecture", is the absence of specific architectural forms for specific functions. Most forms in Iranian architecture can be adapted to a variety of purposes. In addition, structures for a specific function might assume a variety of forms. "Grube"² uses the "Fouriwan"³ structures popular in Central Asia and Iran, as an example. The four-iwan design is a kind of structure used for some palaces, mosques, schools, caravanserais, and private houses. Unlike traditional European structures, Islamic and Iranian buildings

*Corresponding Author Email: Homankhajehpour@sar.iaun.ac.ir

rarely have displayed an inherent directional or axial quality. In fact, if the building does have an actual physical direction, this often differs from the functional direction. (Hajjar et al. , 2011, 27). The hidden architecture aspect can be seen easily in Safavid's building, therefor upon the need of understanding this dilemma we need to survey different qualities of its architecture.

Literary Review

In contrast to the current understanding of a boundless and infinitely expanding universe, pre-modern Muslims thought of and described the cosmos as being finite, bounded, and with astronomically definable limits. The entirety of the cosmos was graspable by means of geometry, numbers, and the alphabet. It was conceived in the form of concentric circles, at the center of which humans dwelled and at the outer limit stood the all-encompassing divine Throne. Following the Greek model, pre-modern Muslim scientists considered geometry to be a part of the mathematical science, which comprises four divisions: the science of number, whose principle is unity or the number one; the science of geometry, whose principle is the point; the science of astronomy, whose principle is the movement of the sun; and the science of music, whose principle is proportion or the equality of two ratios (Akkach, 2005, 6 & 56).

In the place of original mosque structures or in their neighborhoods, during the Saljoughian⁴ era, a splendid mosque decorated by brick and chalky complements was built and the famous dome of Nezamol-Molk⁵ was added to this part of the

mosque in the Malek Shah era. Being aware of geometrical structure of golden ratio, tried to create a kind of coordination in porches and surfaces by applying this golden ratio (Fig. 2). Looking at the porches can demonstrate the application of golden ratio. The golden ratio is also observable in the arcades of the mosque (Khakzad et al., 2011, 99-101).

MATERIALS AND METHODS Safavid's Historical Background

Safavid's dynasty began in about 1507 AD. Their first base of operation was the city of Tabriz and after that due to political reasons the capital moved to Qazvin by Shah Tahmasb⁶ (Kiani, 2012, 103). But it was a temporary strategy which 30 years later all the glory and power was transported to Isfahan, therefore it is the main cause of the growth of these three major city in their time and one of the most transcended factors to show this changes can be seen in the architecture of that time.

The transformation that occurred in Isfahan was so extreme that every ambassador or politician that came to this city was dazzled by its system and beauty.

Methodology

The basic method that is used in this study is descriptive of patterns and differential proportion methods used in the researching values of size and mold of ancient structures in Iranian Islamic architecture and after that analyzing some of the most important proportion factors of Safavid architecture. The plans that have been analyzed in this paper have been

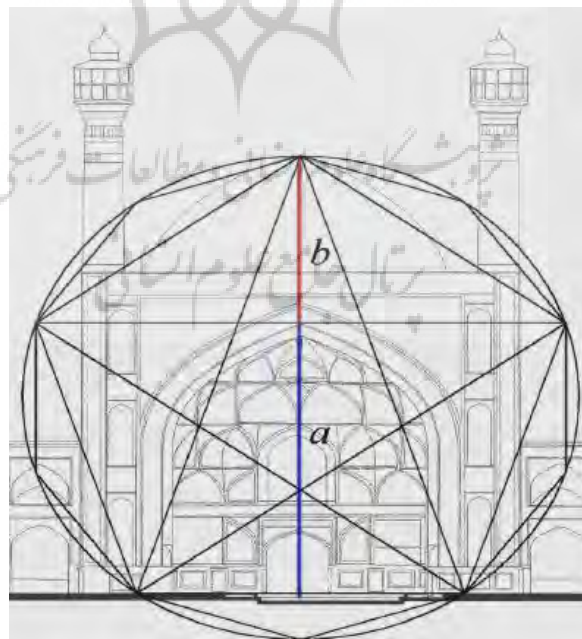

Fig. 2: Golden ratio of the southern side structures of Jame Mosque of Isfahan (Khakzad et al., 2011)

extracted and revised for some of most known authors within this field such as Pirnia (2006 & 2009), Ghobadian (2008), and Naeima (2006). The analytic process is quantified by software and after doing so they have been changed the basic factors to quality values. By assessing the primary data we are able to compare various types of the building within this study.

Proportion and Geometry

In art, proportion is the principle of design concerned with the size relationships of parts of a composition to each other and to the whole. In math, proportion is the ratio or relation of one part or another to the whole with respect to size, quantity, and degree.

Proportionality is something distinct from ratio. proportionality is a similar relationship of two or more ratios. For example, the ratio 2:3, is said to be in proportion to 3:4 because the numerical difference between the first and second number in each ratio is equal to 1 (that is $3-2 = 4-3$) (Masi, 2006, 2).

Many believe that the aesthetic of a building is completely defined by its proportion. Of course this belief is commonly in traditional style such as neo-classicism; therefore it is necessary that we use it to observe the deferential aspects of traditional buildings. Various types of proportion are used in architecture, such as: golden ratio, which is commonly used in European architecture; and Iranian ratio that it can be seen mostly in Iranian historic building.

Golden Ratio

Mathematic systems of proportions originate from Pythagoras hypothesis. Coordinated structure of proportions and especially golden ones can be found in nature; however, the science has proved that this proportion is an actual base proportion of the universe creation. This proportion is visible in the initial forms of nature, including flowers, virus structure, DNA, snails and galaxies (Khakzad et al., 2011, 98). The base of many cultural proportions in ancient Greece and Roman building were prioritized by the golden ratio (Fig. 1).

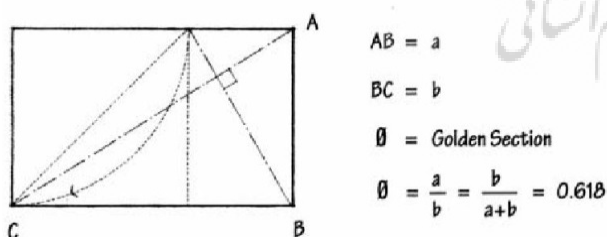

Fig. 1: Golden ratio (Source: Salim Ferwati & Alaa Mandour, 2008, 3)

Proportion in Iranian Architecture

Iranian architecture due to its existence has had at least two types of proportion that have been thought from one generation to another:

Iranian golden proportions: the proportion with the numbers

$\sqrt{2}=1.41$ and $\sqrt{3}=1.73$ is the most ancient architecture of the application and Pirnia professor calls it the golden proportion.

Extensive added: Iranian architecture in addition to the extensive Pymon medley that it is called and used in the proportions set. Meaning to reduce from one, and add to another. But this was something that was very minor used (Ansari et al, 2011, 53).

RESULTS AND DISSCUSION

Mosques

The earliest mosque about which we have reliable archaeological information is the Friday mosque in Isfahan, begun in the eighth century, finally achieving a form not unlike that at Samarkand and reworked repeatedly until the seventeenth century. The original form seems to have been a rectangular multicolumn hall covered with a wooden roof, with a large sahn⁷ at its core. In 1086-87 a domed chamber was introduced at the southwest end of the existing building, probably to serve as a maqsura⁸. It differed significantly in scale from the domes already seen as part of the maqsuras at Damascus and Cordoba: rather than covering one bay of the columnar hall, the southern dome covered twenty bays. In 1088, a slightly smaller dome was added. It is not clear what function it served initially, for it was outside the building at the time of its construction but was soon incorporated into arcades (Moffett et al., 2003, 161). The highest attribute in Islam is and always will be are mosque; therefore it is necessary to understand the basic principle that each generation has for it. Public baths, libraries, hospitals etc. were built around mosques making them cultural or social complex. Such event happened throughout the territory of Muslims and Iran was no exception. One can still observe remains of these complexes in desert cities of Iran (Dehghan et al., 2012, 47).

Imam Mosque of Isfahan

This mosque is considered the symbol of Safavid architecture the rise of it potential. It is located beside Naghsh-e Jahan square⁹ that was the center of Isfahan the time. Imam Mosque in Isfahan during the Safavid dynasty is the most prominent. The review found three major proportions. Important point is that the plan and its proportions are inscribed in a square and that can be considered a $\sqrt{2}$ golden ratio which you can see in figure 3 called forth by Dr. Pirnia (Ansari et al., 2011).

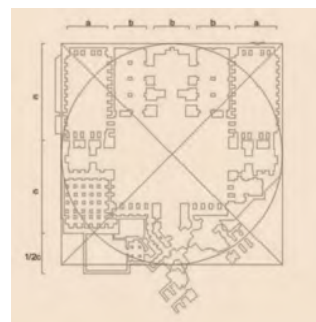

Fig. 3: Imam Mosque of Isfahan plan

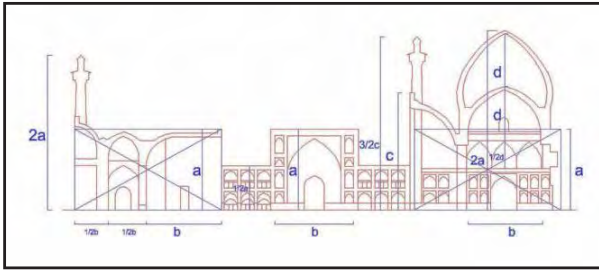

Fig. 4: Imam Mosque of Isfahan facade

The façade has multiple proportions which among them is the most basic and importance. The special factor here is that the two Evans that are in front of each other, have the same basis; therefor both in two similar sized triangle spaces (Fig. 4).

Sheikh Lotfollah Mosque

This mosque was built in 1602-1619 during the Safavid era and is considered one of the best detail oriented building of its time. The uniqueness of his mosque is its design which compared to many other mosque in its region doesn't have some of the basic element such as a courtyard and a monareh¹⁰ (Fig. 5). The proportion values in this building are fairly easy and it is completely connected to the side of the main cubic space.

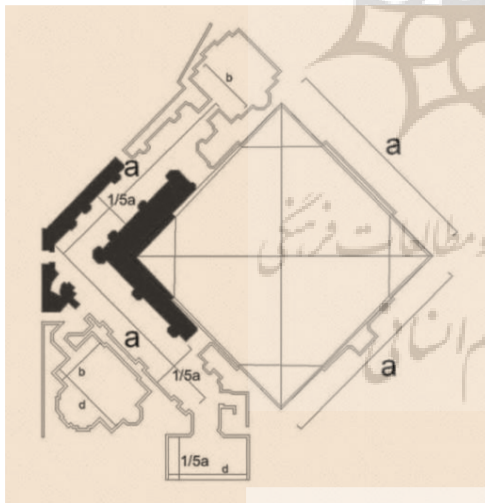

Fig. 5: Sheikh Lotfollah mosque's plan

Due to the uniqueness of this building the compared to other mosques it has a much simpler elevation. The most important proportion value in is the size of the vault with the entrance that have an almost matching cubic size proportion (Fig. 6).

Hakim Mosque¹¹

This is another main mosque built in Isfahan during the Safavid era. The proportion in the plan of this mosque has the same

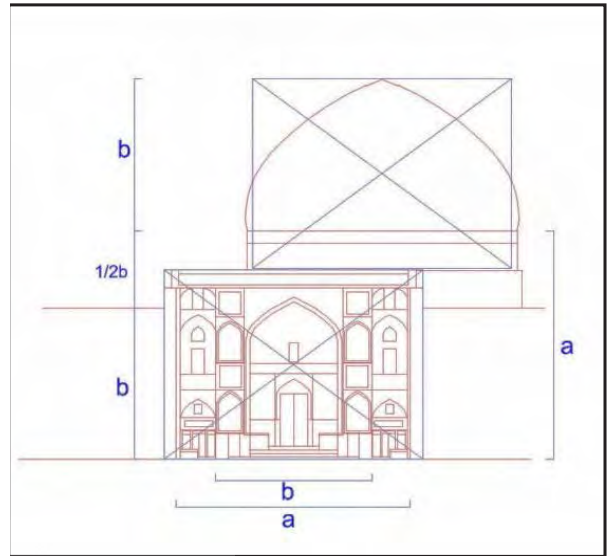

Fig. 6: Sheikh Lotfollah mosque's façade

attribution as the other (Fig. 7) which can be seen the entire plan is inscribed in a cube.

In the façade of this mosque the connection of the two Evans can be seen. Even with the difference of their design the proportion values are similar and another proportion detail that exists is the symmetry of this mosque (Fig. 8).

Governmental Houses

During the Safavid dynasty governmental building found a special value which on till then no government had allowed it. The basic structures of the governmental buildings were obtained

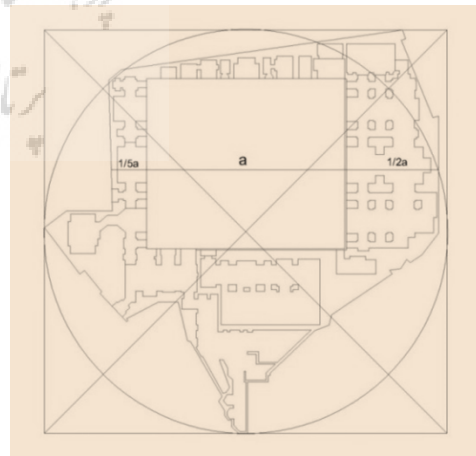

Fig. 7: Hakim mosque plan

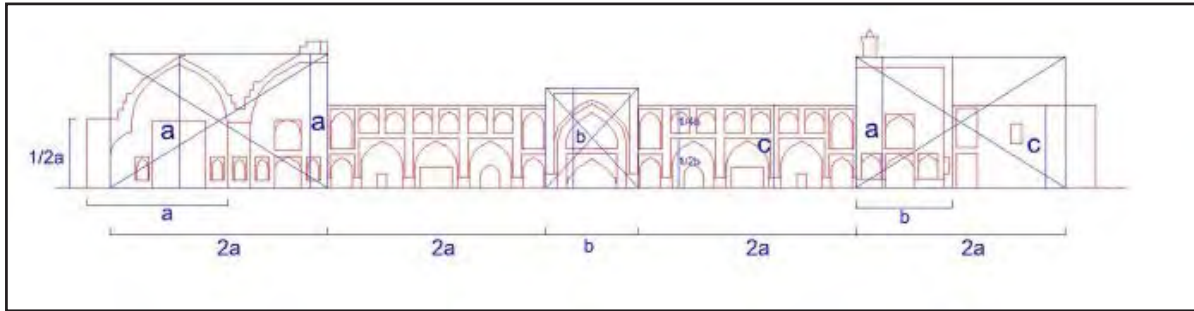

Fig. 8: Hakim mosque façade

from Persepolis's 100 column hall and we can easily understand that they were trying to bring back the grandeur of that time.

Isfahan's 40 Columns¹²

This building is in the middle of a 67000 square meter garden. It was building during the reign of Shah Abase in Isfahan. And the reason they say it has 40 columns is because of the reflection it has in front of it. The important proportion factor

in this building is the usage of the golden ratio in all of the plan design statues (Fig. 9).

There is no comradely use of any golden ratio in the facade of this building; but you can see the three connected bodies that have a complete connection in this structure (Fig. 10).

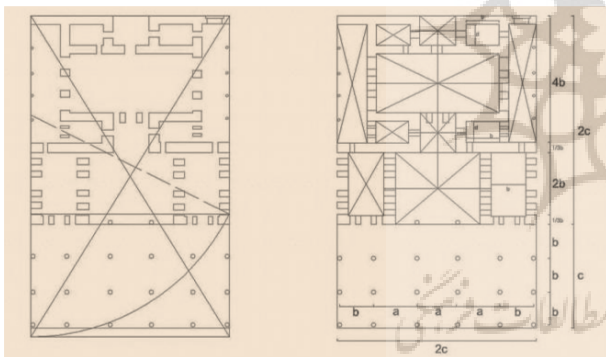

Fig. 9: Isfahan's 40 columns plan

Qazvin's 40 Columns¹³

This building is one of the first governmental complexes made by the Safavids. It has the basic structure and form that was used by their next generations. The use of the golden ratio can be seen in this building (Fig. 11) as well; even so, there are more within the sub structure of this plan.

The façade of this complex, compared to other buildings of it era, has a complicated proportion values (Fig. 12) which shows the valence it had for it time and nation.

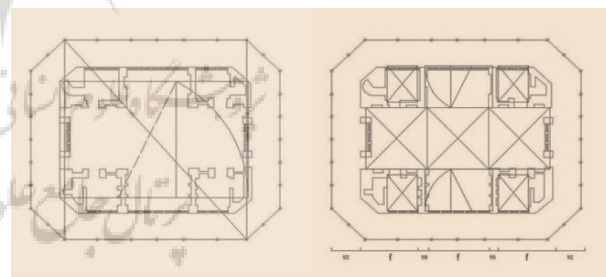

Fig. 11: Qazvin's 40 columns plan

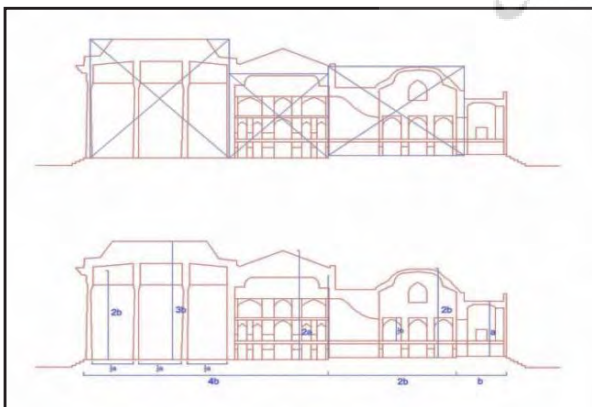

Fig. 10: Isfahan's 40 columns façade

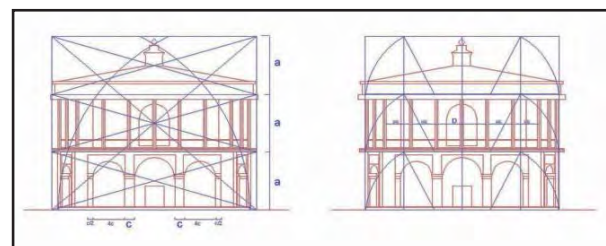

Fig. 12: Qazvin's 40 columns façade

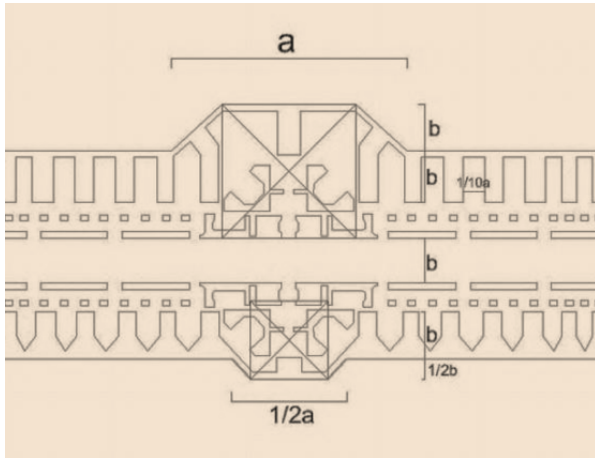

Fig. 13: Khajo Bridge plan

Bridges

Every civilization in history has made various types of bridges during their struggle of life. The basic reasoning of any bridge is to connect two sides and make an economic and simple path; but as a one civilization grows other reasoning such as showing the prosperity of their nation.

Khajo Bridge

This bridge was built as a symbol of Safavid power and had a multipurpose functions; such as, connection, a place for different water ceremonies which upon that chord at the middle of this bridge there is a center space for government officials to enjoy the sport of their time. This functional diversity has caused a complexity in the proportion values of the structure. As it can be seen in the figure 13 most of the virtuosity of proportion in the governor space at the middle of this bridge. There is a small portion of the golden ratio usage in this structure but never the less it is more than mosques. As it can be seen the overall part of the bridge has a basic ratio in its proportion (Fig. 14) and the middle of the bridge has a personal aspect and different idealistic proportion than the other part that has a rhythmic balance.

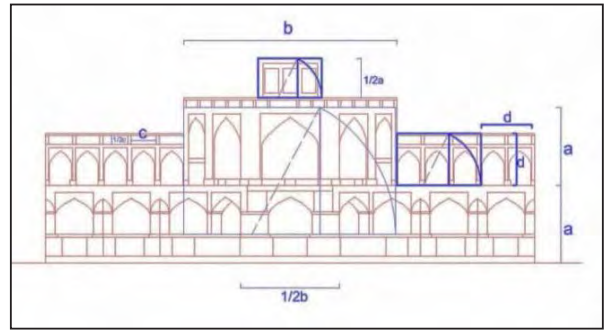

Fig. 14: Khajo Bridge façade

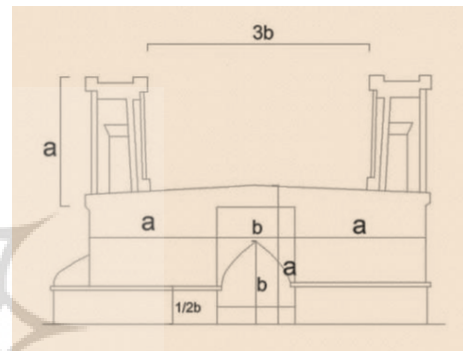

Fig. 15: Isfahan's 33 Bridge facades

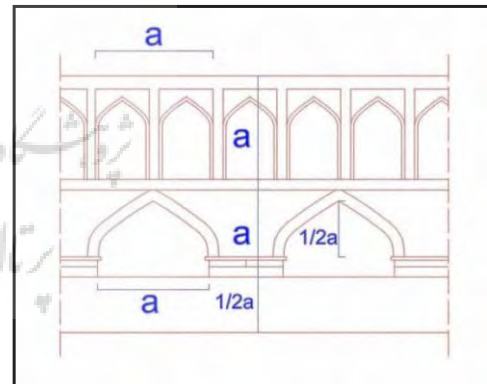

Fig. 16: Isfahan's 33 Bridge facades

Isfahan's 33 Bridge

This bridge was built as a basic connectional bridge for the Safavid's army of the time. The proportion values in the bridge are completely simple and it only has a few connectional size the can be seen in figure15 and 16.

CONCLUSION

Upon analyzing of various proportion values in official and unofficial design of buildings during Safavid era we were able to understand some of the connections in different functional structures of one of Iranian most known architecture vertigo.

One of the most intriguing factors that have been seen is the difference in the golden ratio of the three types of analyzed structures (Table 1).

Governmental buildings had the most use of the golden proportion which might show the value of these structures within the Safavid dynasty and the mosques have a joint Iranian proportion that was common in all of them but at a mediocre aspect bridges had the most simple but enter different

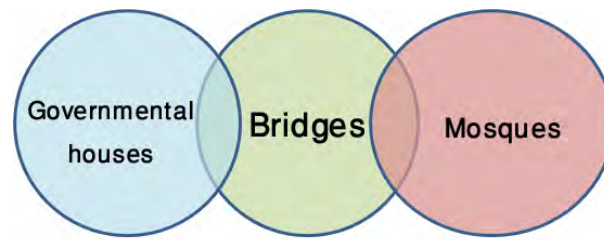

Fig. 17: Proportion connections in Safavid's buildings

Table 1: Overall study of the Safavid period proportion values

	Building's name	Function	Quantity of proportions	Major proportion	Golden proportion	Iranian golden proportions
1	Imam Mosque of Isfahan	General	2	a	-	*
2	Sheikh Lotfollah mosque	General	3	c	-	*
3	Hakim mosque	General	3	a	-	*
4	Isfahan's 40 columns	Governmental/Private	3	c	*	-
5	Qazvin's 40 columns	Governmental/Private	5	f	*	-
6	Khajo Bridge	General/Private	3	a	*	-
7	Isfahan's 33 Bridge	General	2	a	-	-

compared to the other building types (Table 1). Based upon or primary goals we are able to conclude that due to the usage of the golden ratio as a proportion structure (knowingly or invariantly) there is a common aesthetic belief with European architecture. The cause of this action might be due to the increase relation with west nations. As an enter relation of the building, we can see a familiarity between each of the individual categories, especially mosques and governmental buildings. In figure 17 we can see that the proportional systematic relation of the three categories is basically weak and within each building type there is an individual system that makes them unique.

ENDNOTES

1. The dynasty that ruled Iran from 1501 to 1722 (A.D). During this era there first capital was Qazvin and after that it was changed to Isfahan.
2. Sunset
3. It represents the four axis structures mainly in mosques are faced in front of each other within a courtyard. The basic form

is a vault.

4. The dynasty that ruled Iran from 1037- 1194 (A.D.).
5. A known scholar and adviser during the Saljoughi Empire. 1018-1092 (A.D.)
6. The second ruler of Safavid dynasty that declared Qazvin as his capital.
7. Courtyard
8. An area that is reserved for the higher religious class of a society.
9. One of the largest squares in Iran that which plays a pinpoint role in Isfahan's traditional bazar, measuring 165×510 meters (Mojtahedzadeh, 2012, 486)
10. One of the basic elements of many mosques with the purpose of pinpointing the location from far away and using it as a tool to call for prayer. The proper translation is light.
11. One of the oldest mosques in Isfahan that was built in the fourth century (A.D)
12. A structure in a designed Garden which basically has 20 columns but due to their reflection of the pool in front of them