



Original Article

# Validation of the Illinois bullying scale in primary school students of Semnan, Iran

Afzal Akbari Baloobangan<sup>1</sup>; Siavash Talepasand<sup>2\*</sup>

<sup>1</sup>Ph.D. student of educational psychology, Semnan University, Semnan, Iran

<sup>2</sup>Associate professor of psychology and educational sciences, Faculty of psychology and educational sciences, Semnan University, Semnan, Iran

## Abstract

**Introduction:** Bullying in school is one of the major problems in education systems around the world and assessment of the psychometric properties of this concept is important. Therefore, the aim of this study was to validate the Illinois bullying scale in primary school students.

**Materials and Methods:** In this study, 607 students of Semnan were selected through stratified sampling method in the academic year 2013-14 in Semnan. Research instruments included Illinois bullying scale and Harter's motivation questionnaire. For data analysis, factor analysis method, Cronbach's alpha coefficients, and Pearson correlations were done using SPSS-22 and LISREL 8.54.

**Results:** Exploratory factor analysis, item-total correlation, and reliability analyses were undertaken to assess the psychometric properties of the Illinois bullying scale. In addition, confirmatory factor analysis was administered to assess the measurement model and internal relations construct of items. Cronbach's alpha coefficients were 0.87 for the total scale, 0.71 for victims, 0.77 for bullying, and 0.76 for the fighting subscales; all of which were satisfactory.

**Conclusion:** The Persian version of Illinois bullying scale has acceptable psychometric properties and can be used as a reliable and valid instrument in psychological research.

**Keywords:** Bullying, Reliability, Scale, Validity

## Please cite this paper as:

Akbari Baloobangan A, Talepasand S. Validation of the Illinois bullying scale in primary school students of Semnan, Iran. *Journal of Fundamentals of Mental Health* 2015 July-Aug; 17(4): 178-85.

## Introduction

Bulling in schools has been currently introduced as an important and universal problem concerning psychology and social health (1) and it's one of the problematic behaviors that different researchers especially educational psychologist, health and education researchers. Teacher and parents all around the world pay much attention to that (2,3). Bullying in various studies has been introduced as a universal problem, which is continuously being increased, meaning that bullying and annoyance can be shown not only by students in school but also by most of the adults in other environments (4). Bullying, especially among school children, has been stated as a public health problem both at internal and international levels (5). Bullying is mentioned as a unilateral matter (6), which has been defined in different contain three main characteristics including

intentional, repeated, and power imbalance, between a bully and a victim (7) Bullying has also been referred as a systematic abuse of power (8) which is the most common form of violence in school (9). But also in universities, classroom, self-service, and school buses (10). On the other hands bullying is considered as a problematic behavior which affects academic achievement, social skills, mental health and agents (subject of bulling) (11) & is one of the factors which decreases the quality of education in schools (12). Thus primary and secondary schools have changed into an appropriate area for bullying & an avoidable, inappropriate & unpleasant place for bullying victims. In fact Bullying is mentioned as low-level aggressiveness (13) and it's not the simple event like kidding, but its power abuse by one person against the other (6). The results of the study have indicated that about 30 percent of American teenagers experienced to be bully, victim, or both of them (5). It's clear that bullying is different from fight or quarrel between two people who are socially and physically equal; But there is social and physical imbalance in that (14).

\*Corresponding Author: Faculty of psychology and educational sciences, Semnan University, Mahdishahr, Semnan, Iran  
stalepasand@smnan.ac.ir

Received: Apr. 21, 2014

Accepted: Jan. 25, 2015

So, we should not consider all contradictions at school as bullying; but bullying is a subset (conflicts) of contradictory behaviors which appears in different degrees of intensity and seriousness (15). Bullying has different physical, verbal and relational, or social forms (16). Physical bullying consists of damaging, pushing, kicking, etc. and verbal irritation consists of giving a bad name on people, verbal irritation, cursing, threatening, etc. which usually appear directly, but relational bullying is indirectly indicated like intentional social privation, spreading rumors (17), sending an insulting message via electronic post, etc (18). Different studies performed a bullying show that boys are more involved in physical and direct bullying while girls show such behaviors in directly (17). Disruption, smoking, and drinking have been mentioned, too (19). So, bullying can have long and short-term effects on mental and physical health of the students. Furthermore, it may influence student's relationships with school and their self-confidence (12).

Earlier studies focused on a self-report criterion to measure bullying (20), but later researcher compiled various questionnaires based on literature and theoretical principles which were about bullying. Illinois bullying questionnaire which was made by Espelage and Halt, is one of the most reliable instruments for evaluation of bullying. At first, researchers made a twenty one- item questionnaire and indicated factor analysis of three factors including bullying, victim, and fight, but three items were eliminated from the questionnaire because of low correlation with from total test grade (lower than 0.3) and eighteen-item questionnaire was prepared to measure bullying (21). The researchers performed. Illinois bullying scale on eight to eighteen-year old students in Pakistan. Results confirmed the factor analysis of three factors mentioned by the producers of this instrument so that they stated that this scale is a proper instrument for measuring bullying amount & reported the reliability coefficient of this scale by using Cronbach's Alpha method for total test and each of subscales (22). Furthermore, previous studies represented the relationship between bullying and academic achievement meaning that increasing bullying in schools decreases student's academic achievement (12,23). According to the studies, the students who show more physical and verbal violence in classrooms have lower academic activities significantly, compared to others (24). Also, in different countries, bullying has been considered as something that wipes out discipline at

schools and affects the student's absence and runaway from school (25, 26 & 27). On the other hand, the results of the researches show that bullying decreases academic motivation of students (11, 28). Regardless of considering bullying as a unit or multi factor phenomenon, different studies showed that it's a wide and comprehensive phenomenon as if about 40-45% of children are exposed to bullying or victimization (1).

Based on the present literature and review of previous literature, foreign researchers paid attention to bullying and anti-bullying methods in schools seriously, but in our country, Iran, the researchers are going to study the psychometric characteristics of Illinois bullying scale (IBS) because of limitation of studies and lack of appropriate instrument for measuring this construct and importance of this subject.

### Materials and Methods

The present study's design is of correlation type. The statistical universe of this study was all male students in 4th, 5th, and 6th, grades of elementary public schools in Semnan who were studying in 2013-14 academic year in this city. After taking certificate for performing the from chief ministry of education in Semnan and getting agreement from authorities of Ministry of Education in Semnan, 607 students were chosen by multi stage sampling, For sampling, two schools from every geographical region of Semnan (north, center, & south) were chosen and in every school, students who were studying in 4th, 5th and 6th grades of elementary school completed the research instruments. If there were two classes for every grade, one of them would be chosen randomly. To answer the questionnaires items, the researchers themselves distributed them among the sample group and after getting their conscious agreement, the groups were asked to complete the instrument. After that, in order to keep their moral principles, the group made sure that their information will remain confidentially. The following instruments were used for data collection.

A) *Illinois Bullying Scale (IBS)*: It was developed by Espelage and Holt. The scale consists of eighteen items which measures three factors including bulling (I annoyed other students), fight (If someone beats me firstly I will beat him/her), and victim (Other students beat and pushed me). The questionnaire contained a 5-item Likert Scale (never=0, up to seven times or more= 4).

Items of every subscale including (items: 1, 2, 8, 9, 14, 15, 16, 17, 18), subscale of victim (items 4, 5, 6, 7), validity and Reliability. Espelage and Holt

performed this scale on 422 students (214 girls and 208 boys) in sixth, seventh, and eighth grades. In order to determine the validity of the questionnaire, Cronbach's Alpha Coefficient and retest methods were used. According to these methods, the validity of Alpha coefficient and retest were 0.83 and 0.88, respectively. Also Cronbach's Alpha coefficient for each of the subscales includes bullying subscale 0.87, fight subscales 0/83, and victim sub scale 0.88 (21).

*B) Harter's Academic motivation Questionnaire:* The instrument used in this study is the modified form of Harter's Scale as an instrument for measuring academic motivation. Herter's main scale measures academic motivation by using dipolar questions; one is intrinsic motivation and the other is extrinsic motivation. The subject answers to the topic of each question only can have an intrinsic or extrinsic reason. The method of questionnaire grading was based on Likert Spectrum which follows never (grade 1), rarely (grade 2), sometimes (grade 3), often (grade 4), and almost always (grade 5) certainly, this grading method will be reversed in items 3, 4, 5, 9, 10, 15, 16, 19, 21, 27, 23. Validity and Reliability: Validity coefficient of retest and Cronbach's Alpha for total Scale of intrinsic motivation were 0.86 and 0.85, respectively, and for total scale of extrinsic motivation were 0.69 and 0.72, respectively. Coefficients of subscale also were between 0.62 and 0.81 (29). The questionnaire was firstly translated into Persian by two English specialists to perform the research, and then the problems concerning translation of items were studied and solved given to a sample with thirty students in a preliminary study. After collecting the questionnaire, incomprehensive words were rewritten and replaced by the closest words. Final questionnaire was given to 600 students. 23 questionnaire were incomplete or perhaps. They

weren't delivered at all. The final data were analyzed by SPSS-22 and LISREL 8.54 software's.

**Results**

The data derivate from 574 students were analyzed. Exploratory factor analysis: In order to determine the number of factors and study the characteristics of 18 items, bullying scale of exploratory factor analysis was performed for the factor analysis, adequacy index of sampling (KMO) and value of Chi square Bartlett test were calculated. The value of KMO was 0.886 in this analysis. The value of Chi square Bartlett Test was 2.676 which was significant with degree of freedom 136 ( $P \leq 0.001$ ). As a result, in spite of sampling adequacy, performing, factor analysis based on the studied matrix was also justifiable. In order to determine a number of factors that saturated bullying, three following indices were considered: 1. Special value, 2. the ratio of explained variance by each factor and 3. Screen plot. Thus, three factors were extracted which totally determine 49.80 percent of total variance of the test. Studying scary chart and total explained variance show that there is a primary and major factor with two other factors in which specific value amounts of first, second, and third factors are 5.67, 1.68, and 1.19, respectively. Furthermore the explained variance amounts by each of factors including bullying, fight, and victim are 33.34, 9.88, and 6.58, respectively. Items in Illinois bullying scale (IBS) have been reported by using a method for determination of major component in Table 1. As it can be seen in table 1, all factors loading are proper and appropriate except the first item which was eliminated because of having inappropriate factor loading. The lowest factor loading is 0.738 which belongs to item 14 while the highest factor loafing is 0.791 which belongs to item 5.

**Table 1.** Illinois bullying scale factors (bullying, fighting and victimization)

Item	Question	Bullying	Fighting	Victimization
15	I spread rumors about other students.	0.713		
18	I excluded other students from my clique of friends.	0.632		
2	In a group I teased other students.	0.571		
9	I teased other students.	0.557		
8	I helped harass other students.	0.505		
17	I encouraged people to fight.	0.501		
16	I started (instigated) arguments or conflicts.	0.485		
14	I was mean to someone when I was angry.	0.387		
10	I got in a physical fight.		0.746	
13	I hit back when someone hit me first.		0.733	
12	I got into a physical fight because I was angry.		0.674	
11	I threatened to hurt or hit another student.		0.485	
3	I fought students I could easily beat.		0.431	
5	Other students made fun of me.			0.791
6	Other students called me names.			0.756
4	Other students picked on me.			0.647
7	I got hit and pushed by other students.			0.585

Confirmatory factor analysis: At first, unit and multi variability skewers of data were studied and maximum estimations of likelihood were used. In order to measure model fitness, Root Mean Square Error of Approximation (RMSEA), Standardized Root Mean Square Residual (SRMR), Comparative Fit Index (CFI), Goodness of Fit Index (AGFI) was used. Various sections (cuts off) have been introduced for fitness indices by experts and specialists. For example, equal quantity/value or less than 0.05 for root mean square, error of approximation, equal value or more than 0.96 for comparative fit index, equal value or less than 0.07 for standardized root mean square residual indicate adequate model fitness (30). On the other hand, it is suggested that if comparative fit index, goodness of fit index, and adjusted goodness of fit index are more than 0.9 while root mean square error of approximation and standardized root mean square residual are less than 0.05, they will indicate highly ideal and desirable fitness. If their value is less than 0.1, it will show desirable fitness (31). Fitness indices of final form of the questionnaire were examined. Findings indicate desirable Fitness of data- model. In this mode  $X^2=477.85$ ,  $df=116$ , so it gives  $X^2/df=4.11$  Other fitness were desirable, too. standard courses were significant. Item 9 had acceptable validity for the bullying factor ( $R^2=0.45$ ), estimating the validity for items 2 and 6 was acceptable, too ( $R^2=0.37$  and  $R^2=0.35$ , respectively).

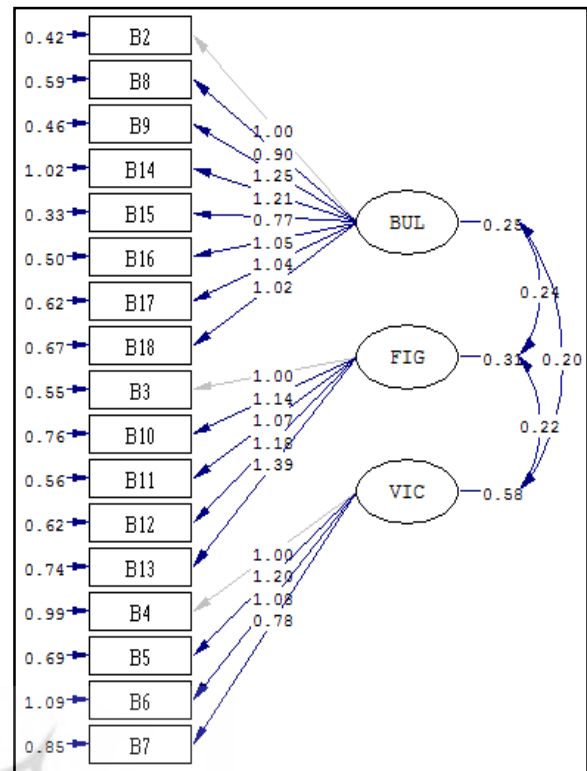

Figure 1. Final measurement model of Illinois Bullying scale

Estimating parameters: As the three-factor model with seventeen items showed proper fitness, standard coefficient, error sentences, and explained variance ( $R^2$ ) were studied (chart 3). All the

Table 2. Fitness indices for final form of three-factor model Illinois bullying scale

Model	$X^2$	CFI	RMSEA	RMSEA CI 90%	SRMR	GFI	AGFI
Three-factor	477.85	0.94	0.074	0.067- 0.081	0.059	0.91	0.88

\* Chi square in maximum likelihood method  
 RMSEA: Root Mean Square Error of Approximation  
 SRMR: Standardized Root Mean Square Residual  
 CFI: Comparative Fit Index  
 AGFI: Goodness of Fit Index

But estimating items including 8, 14, 18, 15 and 17 was relatively low ( $R^2=0.25$ ,  $R^2=0.26$ ,  $R^2=0.28$ ,  $R^2=0.30$  and  $R^2=0.30$  respectively). As a result, the most reliable and powerful indicator of hidden construct of bullying was item 9 ( $\lambda_{91} (s\ tand) = 0.79$ ) and item 2, 16, 17 and 15 are followed by that ( $\lambda_{21} (s\ tand) = 0.61$ , ( $\lambda_{161} (s\ tand) = 0.60$ , ( $\lambda_{171} (s\ tand) = 0.55$  and ( $\lambda_{151} (s\ tand) = 0.55$  respectively) on the second factor. That is fight, estimating item 13 was acceptable ( $R^2=0.45$ ), estimating validity of item 12, 11, 3, and 10 has been acceptable, too ( $R^2=0.41$ ,  $R^2=0.39$ ,  $R^2=0.36$  and  $R^2=0.35$  respectively). The most reliable and powerful indicator of hidden construct of fight is item 13 ( $\lambda_{132} (s\ tand) = 0.67$ ) and items 12 ( $\lambda_{122} (s\ tand) = 0.64$ ), 11 ( $\lambda_{112} (s\ tand) = 0.62$ ), 3 ( $\lambda_{32} (s\ tand) = 0.60$ ), and 10 ( $\lambda_{102} (s\ tand) = 0.59$ ) are followed by

that. Furthermore, on the third factor, that is victim, item 5 had acceptable validity ( $R^2=0.55$ ), estimating the validity for item 6 and 4 had been acceptable, too ( $R^2=0.38$  and  $R^2=0.37$ , respectively). But estimating item 7 was relatively low ( $R^2=0.29$ ). The most reliable and powerful indicator of hidden construct of victim is item 5 ( $\lambda_{53} (s\ tand) = 0.74$ ) and item 6, 4 and 7 ( $\lambda_{63} (s\ tand) = 0.62$ , ( $\lambda_{43} (s\ tand) = 0.61$  and ( $\lambda_{73} (s\ tand) = 0.54$ , respectively) are followed by that.

The reliability analysis of Illinois's bullying scale (IBS): The reliability of Illinois scale (IBS) was calculated by using intrinsic consistency method and Cronbach's Alpha coefficient. The finding showed that the reliability of Illinois bullying scale (IBS) is 0.87. Furthermore victim 0.71, bullying 0.77, and

fight 0.76 were obtained. So the validity coefficient of the total scale and each of subscales has been high which shows high reliability capability of the instrument. Thus Cronbach's Alpha coefficient, differentiation coefficient, and Alpha Coefficient in case of elimination of any item for each of subscales, have been shown in Table 4.

**Table 3.** Estimating standard parameters of Illinois bullying scale

Factor	Item	Standardized Coefficients	Error variance	Determination Coefficients
Bullying	2	0.61	0.63	0.37
	8	0.50	0.75	0.25
	9	0.67	0.55	0.45
	14	0.51	0.74	0.26
	15	0.55	0.70	0.30
	16	0.60	0.64	0.35
	17	0.55	0.70	0.30
	18	0.53	0.72	0.28
Fighting	3	0.60	0.64	0.36
	10	0.59	0.65	0.35
	11	0.62	0.61	0.39
	12	0.64	0.59	0.41
	13	0.67	0.55	0.45
Victim	4	0.61	0.63	0.37
	5	0.74	0.45	0.55
	6	0.62	0.62	0.38
	7	0.54	0.71	0.29

As item is seen in the above, all the calculated differentiation coefficients are suitable and appropriate. The lowest differentiation coefficient (the modified correlation of the item with total grade of scale) in victim subscale which belongs to item 4 with 0.462 and the highest differentiation coefficient are 0.600 which belongs to item 5. Also for fight subscale, the lowest differentiation coefficient, 0.484, belongs to item 3, which the highest differentiation coefficient, 0.602, belongs to item 13. Furthermore, if we delete each of the items, Alpha coefficients won't exceed the standard value. Thus, none of the items of victim and fight subscales were eliminated. In spite of that, the findings showed that the lowest differentiation coefficient in bullying subscale is 0.430 which belongs to item 14, while the highest differentiation

coefficient is 0.575 which belongs to item 9. Item 1 of the questionnaire was in this subscale and its differentiation coefficient was 0.27. As a result, this item was eliminated.

**Table 4.** Cronbach's Alpha, differentiation and Alpha coefficient in case of eliminated item for victim, fight, and bullying subscale

Item	Discrimination coefficient	Cronbach's Alpha if Item Deleted
4	0.462	0.68
5	0.600	0.59
6	0.530	0.64
7	0.426	0.69
Alpha for Victim		0.71
3	0.484	0.74
10	0.523	0.73
11	0.522	0.73
12	0.547	0.72
13	0.602	0.70
Alpha for Fight		0.76
2	0.527	0.74
8	0.446	0.75
9	0.575	0.73
14	0.430	0.76
15	0.512	0.75
16	0.466	0.75
17	0.470	0.75
18	0.454	0.75
Alpha for Bullying		0.77

Convergent, divergent, and criterion validity: In order to calculate the convergent, divergent and criterion validity of Illinois bullying scale (IBS), Harter's academic motivation questionnaire, absence from school, discipline grade, and academic achievement were used at the same time (chart 5). The findings indicated that there is a positive and significant relationship between total score of bullying scale and absence from school at level  $P \leq 0.01$ . Furthermore, there is a negative and significant relationship at level  $P \leq 0.01$  between bullying scale with academic motivation (-0.248), academic achievement (-0.299), and discipline grade (-0.256) of the students. Also, it can be seen a significant relationship between bullying subscales (victim, fight, and bullying) with abovementioned variables.

**Table 5.** Correlation of bullying scale and it subscales with absence from school, discipline grade, academic achievement and academic motivation

Variables	Mean	SD	1	2	3	4	5	6	7	8
1. Bullying total	0.73	0.57	0.87							
2. Bullying subscale	3.74	4.11	0.87*	0.77						
3. Fight subscale	3.87	3.13	0.83*	0.68*	0.76					
4. Victim subscale	2.88	3.00	0.73*	0.42*	0.41*	0.71				
5. Absence from school	0.50	1.42	0.18*	0.19*	0.08**	0.11**	1			
6. Discipline score	17.54	1.20	-0.26*	-0.25*	-0.26*	-0.06	-0.24*	1		
7. Academic achievement	17.17	1.12	-0.30*	-0.27*	-0.28*	-0.15*	-0.25*	0.70*	1	
8. Academic motivation	3.46	0.47	-0.25*	-0.29*	-0.24*	-0.16*	-0.03	0.11*	0.14*	0.76

\*\* $P < 0.05$  \* $P < 0.01$

Alpha coefficient is on the subordinate diameter.

## Discussion

Bullying is a kind of violence which threatens the well-being of teenagers and youths at schools and district. Bullying affects families, schools and people in the society. It may cause lack of self-confidence, fear and humiliation among youths via aggressive actions of others. Bullying accrue in a lot of environment such as schools, after-school programs, or among the youths' districts. So bullying originates from complex factors concerning individual characteristic of youths, their relationship with peers and adults school and / or society norms (32). To do this, the present research aims to study the psychometric characteristics of Illinois bullying scale among elementary school students in Semnan. By using multi-stage sampling method, 607 students were chosen and completed research instruments.

Factor analysis, Cronbach Alpha coefficient and Pearson correlation method were used to analyze data. In order to determine a number of factors and to study the characteristics of bullying scale, discovery factor analysis was performed on the whole sample. The major components were analyzed to extract factors. The finding indicated that the bullying questionnaire has been saturated by three factors. Given the theoretical principles of the research and contents of items concerning the factors and according to the previous studies (21,22,32) which believed bullying has three dimensions, these three factors were labeled as bullying, victim and fight. The results of factor confirmatory analysis indicated that all indices of goodness of fit and all the standard courses were significant and confirmed three dimensions of bullying scale. To examine the validity of Illinois bullying scale, Cronbach's Alpha coefficient was used. This finding has been coordinated with previous studies (21,32).

To examine the validity of Illinois bullying scale, Cronbach's Alpha coefficient was used. The findings of this research indicated that the validity of bullying scale was high and acceptable. Furthermore, each of the subscale's validity was high which shows that instrument validity coefficient is high. This finding was coordinated with research findings (21,22) which showed that total validity of scale and each of the subscales were high. In order to calculate the validity of bullying scale, it was performed with academic motivation scale, academic achievement grade, absence from school, and discipline grade at the same time, and according to the performed studies (33-39), all of those scales had significant relationship with bullying. The findings of the previous researches

showed that bullying in schools has negative & significant relationship with motivation and academic achievement, for example, it decreases students' motivation. Furthermore, each of the bullying subscales influenced academic motivation and student's achievement and this finding was coordinated with the present study and studies (11,28). Besides, there was a significant relationship between each of the bullying subscales (victim, fight, and bullying) with the above-mentioned scales which were in accordance with previous studies (40-45). Given the simplicity of conducting, grading ease, simplicity of interpretation, the capability of conducting both individually and in a group, practicability and proper reliability and validity of the study, it can be concluded that Illinois bullying scale is a good and appropriate instrument for measuring students' bullying. The first limitation of the present study is that it's not clear how they obtained grades of this instrument are related to actual behaviors in daily life. The second limitation of this study is that there is no evidence concerning the sensitivity of its grades to educational psychological interventions. It's not clear whether the obtained grades of this instrument have necessary sensitivity to anti-bullying interventions or not.

The third limitation is related to place and time domain of the study. This study evaluates students of Semnan schools, so its findings cannot be generalized to the other cities of the country.

Based on the limitations, it can be suggested that bullying grade should be according to the measures of actual behavior in daily life to give evidences concerning elaboration of the grades which result from his instrument in real situations of life. It's not obvious whether high grades in the questionnaire can predict practical bullying behaviors or not. On the other hand, the sensitivity of the grades which result from this instrument against anti-bullying interventions is not clear. As a result, we suggest the researchers to plan some studies in the future in order to realize the grades of the exact section of this instrument for knowing the bullying groups as well as understanding the practical applications of the grades of this instrument for predicting the actual behaviors in the Person's environment. Examining the validity of the obtained grades of this instrument as a means for understanding the sensitivity of treatment interventions can be another pivot of appropriate researches on this instrument. It also is offered to study the relationship of bullying in schools with various variables such as mental health, health promotion, mental health, mental well-being, drug misuse, emotional intelligence,

happiness, etc. to obtain comprehensive knowledge concerning bullying in schools and the relationships of this construct with other constructs which have more capability in respective planning. Furthermore, it can be said that bullying construct is of great importance and we can measure it in other societies such as students, working environment, and even in abstract world.

### Conclusion

Based on the present research results, Persian version of Illinois bullying questionnaire (bullying

behavior scale) has acceptable psychometric characteristics among students. As a result, researchers can use it as a valid and reliable instrument.

### Acknowledgement

This study was approved by Semnan Education office. No grant has supported this study and the authors had no conflict of interest with the results. We extend our appreciation to all elementary school principals who cooperated with this project.

### References

1. Fleming LC, Jakobsen KH. Bullying and symptoms of depression in Chilean middle school students. *Online J Pub Health Inform* 2009; 79(3): 123-35.
2. Patchin JW, Hinduja S. Traditional and nontraditional bullying among youth: A test of general strain theory. *Youth Society* 2011; 43(2): 727-51.
3. Nasel TR, Overpeck M, Pilla RS, Ruan WJ, Simons-Morton B, Scheidt P. Bullying behavior among us youth: Prevalence and association with psychosocial adjustment. *J Am Med Assoc* 2001; 285: 2094-100.
4. Hoover J, Stenhjem P. Bullying and teasing of youth with disabilities: Creating positive school environments for effective inclusion. *National Center on Second Education and Transition Issue Brief* 2003; 2(3): 1-6.
5. Bradshaw C, Sawyer A, O'Brennan L. Bullying and peer victimization at school: Perceptual differences between students and school staff. *School Psychol Rev* 2007; 36(3): 361-82.
6. Dadgar R. [9 Strategy on the prevention of bullying]. *Journal of special education* 2009; 102: 68-73. (Persian)
7. Placke KM, Elementary H. Bullying in school. Ph.D. Dissertation. Pennsylvania State: Pennsylvania State University, 2006: 12.
8. Rigby K, Bagshaw D. Prospects of adolescent students collaborating with teachers in addressing issues of bullying and conflict in schools. *Educ Psychol* 2003; 32: 535-46.
9. Brown C, Patterson ST. Bullying and school crisis intervention. *Int J Hum Soc Sci* 2012; 2(7): 1-6.
10. Meyer-Adams N, Conner B. School violence: Bullying behaviors and the psychosocial school environment in middle schools. *Child School* 2008; 30(4): 211-21.
11. Boulton MJ, Trueman M, Murray L. Associations between peer victimization fear of future victimization and disrupted concentration on class work among junior school pupils. *Br J Educ Psychol* 2008; 78: 473-89.
12. Holt M, Finkelhor D, Kaufman Kantor G. Hidden forms of victimization in elementary students involved in bullying. *School Psychol Rev* 2007; 36(3): 345-60.
13. Chen JK, Astor RA. School Violence in Taiwan: Examining how western risk factors predict school violence in an Asian culture. *Interpers Viol* 2010; 25(8): 1388-410.
14. Salmivalli C, Peets K. Bullies, victims and bully-victim relationships in middle childhood and early adolescence. In: Rubin KH, Bukowski WM, Laursen B. (editors). *Handbook of peer interactions, relationships, and groups*. New York: Guilford; 2009: 322-40.
15. Olweus D. Bullying or peer abuse at school: Facts and intervention. *Curr Direct Psychol Sci* 1995; 4(6): 196-200.
16. Crick NR, Grotpeter JK. Relational aggression, gender, and social psychological adjustment. *Child Dev* 1995; 66: 710-22.
17. Owens L, Shute R, Slee P. Guess what I just heard: Indirect aggression among teenage girls in Australia. *Agress Behav* 2000; 26: 67-83.
18. Ma X. Bullying and being bullied: To what extent are bullies also victims? *Am Educ Res J* 2001; 38(2): 351-70.
19. DeRosier ME, Kupersmidt JB, Patterson CJ. Children's academic and behavioral adjustment as a function of the chronicity and proximity of peer rejection. *Child Dev* 1994; 65(6): 1799-813.
20. Crick NR. The role of relational aggression, overt aggression, and prosocial behavior in the prediction of children's future social adjustment. *Child Dev* 1996; 67: 2317-27.

21. Espelage DL, Holt MK. Bullying and victimization during early adolescence: Peer influences and psychosocial correlates. *J Emot Abuse* 2001; 2(2-3): 123-42.
22. Shujja S, Atta M. Translation and validation of Illinois bullying scale for Pakistani children and adolescents. *Pakistan journal of of social and clinical psychology* 2011; 9: 79-82.
23. Hanish LD, Guerra NG. Aggressive victims, passive victims and bullies: Developmental continuity or developmental change? *Merrill Palmer Q* 2004; 50: 17-38.
24. Roman M, Murillo FJ. Latin America: School bullying and academic achievement. *Cepal Rev* 2011; 104: 37-53.
25. Skrzypiec G. Living and learning at school, document presented at the Annual Conference of the Australian Association for Research in Education. Available from: <http://www.aare.edu.au/08pap/skr081125.2008>.
26. Dake J, Price J, Telljohann S. The nature and extent of bullying at school. *J School Health* 2003; 73: 5.
27. Aguilera M, Munoz G, Orozco Disciplina A. [Violencia consumo desustancias nocivas a lasalud en escuelas primarias secundarias de Mexico]. Mexico City: National Institute for Educational Assessment and Evaluation; 2007: 33. (Mexican)
28. Strqm IF, Thoresen S, Wentzel-Larsen T, Dyb G. Violence, bullying and academic achievement: a study of 15-year-old adolescents and their school environment. *Child Abuse Negl* 2013; 37(4): 243-51.
29. Bahrani M. [Validity and reliability Harter's academic motivation scale]. *Journal of psychological studies of Alzahra University* 2008; 1: 50-72. (Persian)
30. Joreskog KG, Sorbom D. LISREL 8: User's Reference Guide. Chicago: Scientific Software Inc; 2003.
31. Berkler SJ. Applications of covariance structure modeling in psychology: Cause for concern. *Psychol Bull* 1990; 107: 260-73.
32. Gladden RM, Vivolo-Kantor AM, Hamburger ME, Lumpkin CD. Bullying surveillance among youths: Uniform definitions for public health and recommended data elements, version 1.0. Atlanta, GA; National Center for Injury Prevention and Control, Centers for Disease Control and Prevention and U.S. Department of Education; 2014: 58.
33. Craig WM. The relationship among bullying, victimization, depression, anxiety, and aggression in elementary school children. *Pers Individ Dif* 1998; 24(1): 123-30.
34. Andreou E. Bully/victim problems and their association with coping behavior in comital peer interactions among school-age children. *Educ Psychol* 2001; 21(1): 59-66.
35. Nansel TR, Overpeck MD, Haynie DL, Ruan WJ, Scheidt PC. Relationships between bullying and violence among US youth. *J Am Med Assoc* 2003; 157(4): 348-53.
36. McDonald G, Leary MR. Why does social exclusion hurt? The relationship between social and physical pain. *Psychol Bull* 2005; 131(2): 202-23.
37. Perren S, Alsaker FD. Social behavior and peer relationships of victims, bully-victims, and bullies in kindergarten. *J Child Psychol Psychiatry* 2006; 47(1): 45-57.
38. Jolliffe D, Farrington DP. Examining the relationship between low empathy and bullying, *Aggress Behav* 2006; 32(6): 540-50.
39. Espelage DL, Bosworth K, Simon TR. Examining the social context of bullying behaviors in early adolescence. *J Couns Dev* 2011; 78(3): 326-33.
40. Boulton MJ. Concurrent and longitudinal relations between children's playground behavior and social preference. *Victim Bull Child Dev* 1999; 70(4): 944-54.
41. Wolke D, Woods S, Bloomeld L, Karstadt L. The association between direct and relational bullying and behavior problems among primary school children. *J Child Psychol Psychiatry* 2000; 41(8): 989-1002.
42. Pellegrini AD, Long JD. A longitudinal study of bullying, dominance, and victimization during the transition from primary school through secondary school. *Br J Dev Psychol* 2002; 20(2): 259-80.
43. McCabe RE, Antony MM, Summerfeldt LJ, Liss A, Swinson RP. Preliminary examination of the relationship between anxiety disorders in adults and self-reported history of teasing or bullying experiences. *Cogn Behav Ther* 2003; 32(4): 187-93.
44. Friedman MS, Koeske GF, Silvestre AJ, Korr WS, Sites EW. The impact of gender-role nonconforming behavior, bullying, and social support on suicide among gay male youth. *J Adolesc Health* 2006; 38(5): 621-23.
45. Urton KA, Florell D, Gore JS. Differences in proactive and reactive aggression in traditional bullies and cyber bullies. *J Aggress Maltreat Trauma* 2013; 22(3): 316-28.